

Outcomes Framework for Dance Movement Therapy©

TOWARDS FLOURISHING INDIVIDUALS AS EVIDENCED IN OVERALL VITALITY AND ALIVENESS

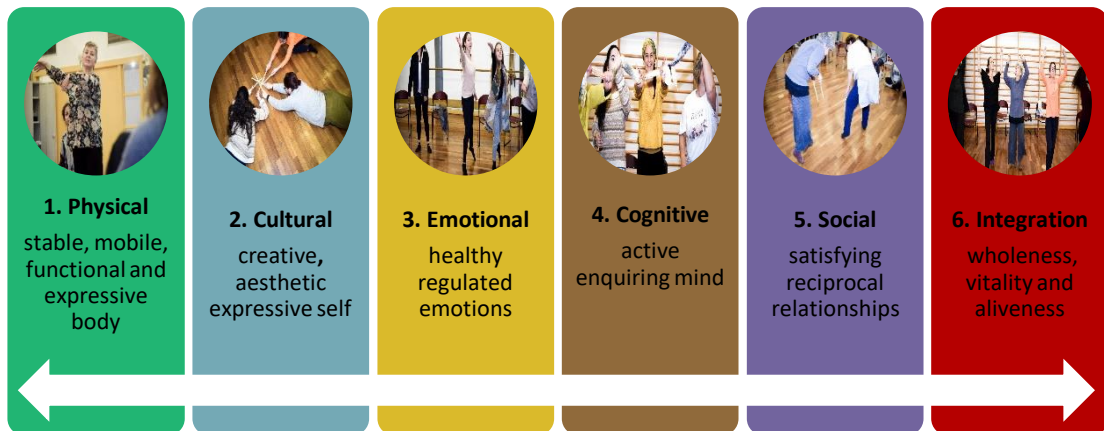

Kim Dunphy, Paula Lebre and Sue Mullane
November 2020

Please cite as:

Dunphy, K., Lebre, P., & Mullane, S. (2020). *Outcomes Framework for Dance Movement Therapy*. V. 81.
www.makingdancematter.com.au

TABLE OF CONTENTS

OVERVIEW: OUTCOMES FRAMEWORK FOR DANCE MOVEMENT THERAPY.....5

ABOUT THE OUTCOMES FRAMEWORK6

What it is.....6

Why it is needed6

About Outcomes Frameworks more broadly.....6

How it was developed6

What it is for.....6

Outcome Domains7

How it works7

Functions of assessment9

Other potential contributors to assessment.....12

Individual and group profiles12

ABOUT THE PHYSICAL DOMAIN18

Towards a stable, mobile, functional and expressive body.....18

Fitness and release.....18

ABOUT THE CULTURAL DOMAIN.....22

Towards a creative, aesthetic, expressive self.....22

ABOUT THE EMOTIONAL DOMAIN25

Towards healthy, regulated emotions.....25

ABOUT THE COGNITIVE DOMAIN.....27

Towards an active, enquiring mind27

ABOUT THE SOCIAL DOMAIN.....30

Towards satisfying reciprocal relationships.....30

ABOUT THE INTEGRATION DOMAIN33

Towards wholeness, vitality, aliveness.33

COMPREHENSIVE MODEL DEPICTING RELATIONSHIPS BETWEEN THE DOMAINS.....36

Glossary40

Acknowledgements41

References42

Figures

Figure 1 Group profile: mean score per domain.....13

Figure 2 Group profile: mean score per sub-domain13

Figure 3 Group profile: Mean score per item (objective).....13

Figure 4 Group profile: Mean score per domain: initial and final assessment	14
Figure 5 Group profile: Mean score per sub-domain: initial and final assessment.....	14
Figure 6 Group profile: Mean score per item (objective): initial and final assessment	14
Figure 7 Group profile: Mean scores per domain per session	15
Figure 8 . Group profile: Mean scores per sub-domain per session.....	15
Figure 9 First order six factor model	38
Figure 10 Second order single factor model	39

Tables

Table 1 Outcomes framework overview	5
Table 2 Group profile: mean scores per session, number of sessions scored, mean, standard deviation, minimum value (lowest) score, maximum value (highest) score, median percentile 50%, for items.....	16
Table 3 Group profile: mean scores per session, number of sessions scored, mean, standard deviation, minimum value (lowest) score, maximum value (highest) score, median percentile 50%, for sub-domains and domains.	17
Table 4 Proposed factor structure comprising 6 Domains (Latent variables in CFA).....	36
Table 5 Sub domains : proposed second order six factor structure comprising 17 sub-domains (Latent variables in CFA)	36
Table 6 Proposed Items/objectives (observed variables in CFA).....	37

OVERVIEW: OUTCOMES FRAMEWORK FOR DANCE MOVEMENT THERAPY

This page provides an overview and short version of the *Outcomes Framework*, depicting the six domains, their desired endpoints and their two or more sub-domains. These sub-domains are divided further into objectives, up to ten each, which are described in the complete *Framework* that follows.

The *Framework short version* is suggested as useful for participants, given the reduced complexity, detail and jargon it includes. It may be used in planning for identification of goals, and associated objectives, or as a self-assessment tool for participants, enabling them to consider their progress against the sub-domains.



1. PHYSICAL DOMAIN: Towards a stable, mobile, functional and expressive body
1.1. Body parts: awareness, activation and connection
1.2. Space: Body in space
1.3. Shape: Body shaping
1.4. Effort: Movement qualities
1.5. Fitness and release
2. CULTURAL DOMAIN: Towards a creative, aesthetic, expressive self
2.1. Creativity and aesthetic sense
2.2. Cultural appreciation and belonging
3. EMOTIONAL DOMAIN: Towards healthy, regulated emotions
3.1. Emotional expression
3.2. Emotional regulation
4. COGNITIVE DOMAIN: Towards an active enquiring mind
4.1. Attention and initiative
4.2. Memory
4.3. Executive function
5. SOCIAL: Towards satisfying reciprocal relationships
5.1. Embodied communication
5.2. Social reciprocity
5.3. Expressive communication
6. INTEGRATION DOMAIN: Towards wholeness, vitality, aliveness
6.1. Sense of integration within oneself
6.2. Sense of integration between self and outside world.

Table 1 Outcomes framework overview

ABOUT THE OUTCOMES FRAMEWORK

What it is

This *Outcomes Framework* offers a comprehensive schema of outcomes of dance movement therapy (DMT). The breadth of the frameworks supports the development of an instrument intended to enable assessment of outcomes of DMT for all therapy participants, regardless of presenting issue, age, cultural background, context for therapy and other differences. It is predicated on the assumption that all human beings have the same basic needs and aspirations and therefore can be assessed using the same comprehensive tool, notwithstanding the differences they might be experiencing on any aspect related to the outcomes at the current time, given the factors listed above.

Why it is needed

In many areas of human service, from health to education and community support, there is an increasing priority on outcomes for participants, rather than focus on service delivery or receipt being considered the endpoint. Operation within evidence-informed paradigms is increasingly emphasised (Laska, Gurman & Wampold, 2014; Melnyk, Long & Fineout-Overholt, 2014). Evaluation processes are more regularly part of activity cycles, underpinned more frequently by outcomes frameworks. In programs that seek to support therapeutic change, it is ever more critical for stakeholders including prospective and current participants, therapists, agencies and funders to be able to focus and measure outcomes for participants, to:

- inform choices about which therapy may be appropriate for which participants;
- identify whether, and which, specific approaches or methods are useful for which participants in which circumstances;
- measure whether the work is having the desired effect;
- know when to stop;
- determine cost-effectiveness and value for money.

About *Outcomes Frameworks* more broadly

The use of *Outcomes Frameworks* is a growing practice internationally that enables agencies, sectors and governments to measure progress and enable work towards shared achievements. Outcome schemas are being used in many countries across a wide range of human services, such as government departments of Communities and Justice in Australia (NSW Government, 2019); children in New Zealand (Oranga Tamariki Ministry for Children, n.d.); social services in Wales (Welsh Government, 2016); early childhood services in USA (Head Start Early Childhood Learning and Knowledge Centre, n.d.) and mental health, Department of Human Services, 2008). An international initiative, the COMET (Core Outcome Measures in Effectiveness Trials) (COMET, 2018) has been instigated to support the development and application of agreed standardised sets of outcomes to measure and report in all clinical trials of specific conditions. The Child Outcomes Research Consortium in the UK (CORC, 2020) was founded by a group of mental health professionals to collect and use evidence to improve children and young people's mental health and wellbeing. They encourage the use of routine outcomes measures by service providers that has allowed the collection of data about more than 400,000 children and young people that is used to inform practice and policy. The introduction of such a framework in DMT is new for creative arts therapies but in line with international best practice.

How it was developed

The *Outcomes Framework for DMT's* development began with an evaluation framework for a dance program for participants with intellectual disability first published in Dunphy & Scott (2003). Then it has been expanded through by inclusion of information from theory and empirical research about outcomes of DMT more broadly. The *Framework* has been further expanded and validated with the practice knowledge of more than 100 DM therapists from across the world (including Australia, Canada, China, Germany, Holland, Italy, Korea, New Zealand, Portugal, Switzerland, Taiwan and the USA) who have provided feedback about the outcomes and their definitions.

What it is for

The *Outcomes Framework* has been developed to support dance movement (DM) therapists to assess participants throughout the entire therapeutic journey, from diagnosis, intake, planning to mid-program (formative assessment) through to completion (summative assessment). It therefore supports DM therapists to plan programs, make decisions about therapeutic program goals and objectives and justify specific interventions or activities. It addresses a challenge in the DMT profession of a lack of agreed outcomes and associated measures (Takahashi et al, 2019). It reduces the need for practitioners to develop their own assessment instruments independently, a current practice (ADTA, 2017) that is potentially both inefficient and ineffective. Being sited entirely within DMT, it addresses the ambivalence in the profession about outcome-focussed approaches, especially those involving scientific or numerical assessment tools, which can be seen as reductionist and inadequate to capture the essence of creative therapeutic processes (Meekums, 2010, 2014).

Its breadth of application is intended also to enable the gathering of data from diverse programs and interventions for evaluation purposes, and thus opens the future possibility of aggregation of data across programs and sites. The possibility of larger data sets enabled by aggregation across sites, supported by the data-gathering potential of practitioners have the possibility of enhancing the quality of future studies in the field, which Takahashi et al (2019) recommend as being a critical need for DMT.

Outcome Domains

The *Framework's* content has been drawn from theory, empirical evidence and practice knowledge. Underpinned by a holistic approach to wellbeing the Framework comprises six outcome domains: 1. Physical, 2. Cultural, 3. Emotional, 4. Cognitive; 5. Social and 6. Integration. These domains correspond closely to outcomes of dance movement therapy articulated in definitions provided by DMT professional associations from Australasia (DTAA, 2020), Europe (EADMT, 2020) and USA (ADTA, 2020). They also align with Hanna's (2008) universal descriptors of learning that occurs through dance, comprising Physical, Cognitive, Emotional, Inter-personal and Expressive/ Aesthetic domains (2008) and encompass the three aspects, physical, mental and social, of wellbeing identified by the World Health Organisation (WHO, 2020). While these outcomes are posed here as separate to enable their use as a planning and assessment tool, they are of course, inter-related, intrinsically connected and influencing each other.

Each domain has its own specific endpoint that is posited to be relevant for every individual and for which evidence indicates can be impacted by dance movement therapy. In the Physical domain, this is a stable, mobile, functional and expressive body; in the Cultural domain, this is a creative, aesthetic, expressive self; in the Emotional domain this is healthy, regulated emotions; in the Cognitive domain, this is an active enquiring mind; in the Social domain, this is satisfying reciprocal relationships; and in the Integration domain, this is a sense of wholeness, vitality, aliveness and integration across all areas. The outcomes are ordered in terms of their significance in DMT. The Physical domain, or body, is listed first, as the site of all DMT work and the focus that distinguishes DM therapists from many other types of psychotherapists, counsellors and creative arts therapists. However, dance movement therapists work differently than other therapists whose focus is might also be the physical domain and the body, given the focus in DMT of the expressive aspects of movement and the intention of the mover. Thus, the LBM system is used rather than measures of functional movement because it enables this assessment of why the person is moving as well as what and how they are moving.

The Cultural domain follows next because of DMT's fundamental premise of engagement with creativity and the aesthetic expressive self. This distinguishes DM therapists from other types of professionals who may work with the body but not necessarily in a creative way and is also the domain that DM therapists share with other creative arts and expressive therapists. Then DM therapists work with participants in the Emotional domain, the Cognitive domain and the Social domain, when the participant may work in relationship with the therapist and one or more others. These three domains are all therapeutic foci shared with many other therapists. Then the final domain of Integration enables assessment of the sense of coming together of important aspects of participants' lives. It is in this domain, of integration that spirituality is sited, as the aspect of self where very significant and meaningful experiences occur. The Integration domain also identifies numinous and transcendent experiences for those whom spirituality may not be such a meaningful construct as well as flow, which is another facet of the fully realised self.

The *Framework* and its associated outcomes contribute to the desired endpoint of *flourishing individuals*, with the flourishing understood as Seligman articulates it, of finding fulfillment in our lives, accomplishing meaningful and worthwhile tasks, and connecting with others at a deeper level (Seligman, 2011).

The *Framework* and its outcomes are strengths-based and potential-focussed because DMT, like other arts therapies, works by activating the healthy capacities of patients (Samaritter, 2018), rather than diagnosis or deficit-focus of some other approaches that are shaped towards treatment of pathology. Thus, the therapist using it is looking for the growth and development potential of their participants and assessing the person's progress towards those, rather than the aspects of self in which the person is deficient, inadequate or outside the norm.

Is it relevant for other therapeutic modalities?

The *Outcomes Framework* has been developed specifically for dance movement therapy, through examination of theory, literature and practice knowledge from this field. However, given the close alignment of outcomes of different creative arts therapies, which Jones (2020) argues are largely common to all the modalities, the *Framework* is potentially relevant for other creative arts therapies as well. It might be expected that the Physical domain, especially the aspects of it that require specialist training in LBMS, might be less relevant to other modalities, and there may be additional outcomes more closely related to arts practice of the other modalities that are not included here. A small trial with psychomotor therapists indicated the *Framework's* potential for planning and assessment in that profession (Lebre, Dunphy & Juma 2020). Trials are underway with practitioners in various other creative arts therapy modalities to explore the possibilities for its application in those fields.

How it works

Scoring options

This Framework can be operationalised for assessment in three ways:

1. **in a Word document suitable for single participant**, single session assessment. Useable on a computer or other device that allows Word. Available here <https://www.makingdancematter.com.au/resources/>;
2. **Excel document suitable for single participant, multiple sessions, and groups of participants for multiple assessments**, with embedded formulas to calculate a range of useful data (mean, median, highest

and lowest scores and more) from individual assessment points. Usable on computer or any device that allows Excel. Available here <https://www.makingdancematter.com.au/resources/>;

3. **MARA iPad app that can be used for single participants and groups** for unlimited sessions, offering score calculations as well. Useable on iPad only. Available here <https://www.makingdancematter.com.au/help/>

Sub-domains and objectives/outcomes

Each domain has a number of sub-domains, up to ten, all with associated objectives (in the planning stages) that become outcomes (when they are realised), that are: *specific*, in describing a particular behaviour or response; and *measurable* in that a numerical score can be selected as a judgement about the extent to which that behaviour or response has been demonstrated at that moment and *timely*, in that they occur at a specific moment in time.

Assessment scale

The assessment scale used in the *Framework* is not norm-referenced, (i.e. offering measurement of a participant on items against a 'norm' of people in the population), because each DM therapist works with participants of varying capacities and the *Framework* has been developed to be used with great diversity of participants and contexts. Many other scales are very specific for population groups and therefore scores can be compared to a norm.

How assessment occurs

Thus, assessment using this *Framework* relies on a skilled therapist who knows his/her participant group and individual participant well and uses that information as the basis for judging the participant's progress towards objectives in any session or moment. This assessment occurs intrinsic to the therapeutic process, with assessment objectives not being external to, or in a different modality, than the movement experience. This is different from many other scales used in assessment which are from other disciplines or focus on aspects of the participant's experience that are not central to DMT.

Most items can be assessed from direct observation, while others are potentially assessed by inference from participants' responses that could be enhanced by participants' self-assessment or reflection that could also be given a numerical score. This option does not rely on participants being able to conceptualise, describe or rate their experiences verbally.

Rather, the *Framework* requires the therapist to score the participant using the therapist's judgement of the participant's current capacity on that objective and their performance relative to that. The therapist scores how close s/he believes the participant to be in achieving their current potential, with high scores (highest 10) indicating actualisation of skills and capacity, and low scores (lowest 1) indicating potential as yet under-developed or enacted. This offers the possibility for the scale to be adjusted over time to reflect changes in the participant's capacity (improved or otherwise) as a result of the therapeutic process or other factors.

The point 1 '*not at all*' represents the demonstration of least evidence of progress towards that objective. The point 10 '*maximal conceivable*' represents what the therapist assesses as the peak capacity of that participant within their current circumstances (considering individual ability and environmental support). This requires a judgement of what might be possible for that participant but is not yet evidenced. 1 is used as the lowest point rather than 0, so that the participant never receives a score of themselves or their participation as null. 0 is used to indicate 'not observed'.

It is the therapist's task to find ways to stimulate or elicit the participant's potential through the DMT program. A participant may have capacity as yet unrealised because the opportunity has not been provided to them to reach it.

The numerical score is supported by qualitative case notes that can be included in both the Word and Excel versions. *MARA* also enables a range of other data collection options, media (photo, video, voice and sound recordings). Arts-based methods are also enabled through drawing, sound recording and media options. Best practice in assessment processes emphasize multidimensional assessment, as the reliability and validity of assessment results improve as the number of data collection methods increases.

Selecting goals and objectives for programs and assessment

The circumstances or diagnosis of participants and the contexts of the DMT program or intervention determines the focus of any intervention or program on one or more domains, therapeutic goals and objectives. Therapists and participants might make decisions about objectives together, responding to funding imperatives, organisational goals or other priorities. Thompson (2020) offers a thoughtful process entitled 'client in context' approach to enable therapists and clients to set what she titles as goal 'focus' together. This might be helpful for therapists seeking additional support at this stage.

The *Framework short version*, which includes only *Domains* and *Sub-domains* and their endpoints, can be used for identification of goals as a starting point, reducing the complexity and detail for therapists and participants to consider. This could be complemented with the therapist selecting or suggesting specific objectives within the selected sub-domains.

This *Framework* can function to catalyse the DM therapist to first clearly identify outcomes of the therapeutic process that s/he and the participant have agreed to work towards, and focus intently on assessing the participant's progress towards these, selecting a score for each instance of a movement or other behaviour observed. Previous users report their observations practices being 'sharpened' in using *MARA*, especially in its requirement that a numerical score for each objective must be selected to represent the quality of movement observed (Dunphy, Mullane & Allen, 2016).

Including additional objectives in the *Framework*

The idea of the *Outcomes Framework* is that it currently, or eventually, will include all outcomes that are documented as being achieved through DMT, or that therapists have reported that they look for. This means that therapists should not need to add additional objectives. By having a standard set of outcomes with associated measures that DM therapists use to assess their work, the need for every DM therapist to invent their own measures is eliminated. Having shared measures also increases the effectiveness of those researching and writing about their work, especially because this enables the possibility of datasets that can be joined, compared or otherwise put together.

It's also possible that the description or definition of current outcomes could be adjusted to cover goals that practitioners seek to address that seem not yet to be covered in the *Framework*.

If you have an objective that you think should be included in *the Outcomes Framework*, please email us and we can consider it. It's possible to include new ideas, as long as they fit the criteria (documented as being achieved directly through DMT or that therapists have reported that they look for).

Functions of assessment

When to assess during the program

The Framework can be used for a range of moments in the therapeutic journey:

1. as a diagnostic instrument prior to commencement of therapy, to determine what aspects relevant to DMT a participant or group might have potential for improvement in;
2. at intake, to assess a baseline on any objective at the commencement of therapy;
3. for program planning, to set targets, either by the therapist or participant for themselves;
4. during the therapeutic process, for formative assessment to enable judgements to be made about progress and any need for program adjustment; including the moment that might be right to cease therapy. Ongoing data collected assists the therapists to reflect on their actions in the therapeutic space; informs the collaborative discussion between the therapist and client; and can identify the direction of further development and maintenance of productive and inclusive therapeutic environments, exploring new approaches to engaging and support clients.
5. at the end of the therapeutic program, to determine the right time to stop and assess progress that has occurred.

When to assess in a session

An assessor can decide to assess once in a session at the time a behaviour or movement is observed or multiple times to indicate frequency of occurrence of the behaviour or movement being assessed, or at particular time intervals throughout a session.

This might include:

- a) assessment of each objective undertaken once per session at a certain point that has been decided beforehand, for example, during a particular activity that is intended to elicit the movement behaviour being sought;
- b) a very salient moment (either towards desired objectives or not) that happened during the session that the therapist has observed and wants to record;
- c) assessment occurring at the end of the session to record a score that the therapist decides is representative of the participant's overall performance on that element for the session. This scoring might occur with therapist/s scoring independently or therapist might choose to confer with other colleagues or support workers at the end of the session, to end up with one score each for each participant on the objectives for the session;
- d) one score might be made of every time the element (for example, suddenness) occurs throughout the session. This process would enable the development of a picture of when suddenness is elicited in a participant's movement, and therefore how the therapist might respond. If more suddenness is required for the participant to have a good movement range, then finding the moment that this quality is elicited (for example, when mirroring someone who is very skilful in this quality) would enable the therapeutic program to be adapted to include more of such moments to offer the participant the greatest chance to develop their own capacity;
- e) time interval: assessors might also decide to score at a particular time period throughout the session (such as every five minutes) so that they are sure they are recording all of the participant's capacities, and not just those they are looking for (such as high access to suddenness). This would help reduce the possibility that the therapist only records

the things they are wanting to see and misses all the rest of the time when the participant is not actually being supported to access whatever it might be;

f) micro-analysis: if this process was used in research, micro-analysis approach might be taken, when a score might be made every time a specific quality is evidenced that would enable a whole session to be analysed in minute detail. This type of assessment would likely not be within the scope of a practitioner-therapist offering DMT with participants but might be useful to offer particular insight.

A, b and c are more likely to be useful strategies for therapists assessing as part of their normal practice, and d, e and f more for researchers or therapists who are resourced to do detailed analysis.

How long should a session be to use the *Outcomes Framework* and *MARA* for assessment?

The *Outcomes Framework* and *MARA* can be used in any type or length of session, with the idea that it works for any practice situation. Some therapists have a context in which they have allocated assessment time with individual clients before they begin a therapy program. This is obviously ideal. Other therapists find themselves walking into a room of strangers and beginning a program or a session without any preliminary work with those participants. In either case, the *Framework* and *MARA* can be used: allocated assessment time with an individual client would enable the therapist to develop a proper profile of the client, on which their program planning could be used. Other therapists might have to use the *Framework* and *MARA* during or at the end of a first session to create a profile of participants on which to base further work.

How long should observations or videos of observations be when using the *Framework* and *MARA* for assessment?

MARA is set up to capture 15 second clips. This is based on the theory that 'thin slices' (Ambady, Bernieri & Richeson, 2000) of observed behaviours are equally valid as longer observations. The number of short clips that can be taken by *MARA* is unlimited, so a therapist may wish to record multiple short clips to enable assessment at another time or to provide evidence of qualitative observations or scores made. Shorter video clips are also more portable, and more likely to be able to be suitable as data for other stakeholders who may have limited time to watch lengthy material.

Do I need to record a session to use the *Framework* and *MARA* for assessment?

It is not necessary that a session be recorded for the *Framework* and *MARA* to be used for assessment. These tools have been developed to help dance movement therapists in their everyday practice, where recording might not be desirable because of client privacy issues, the demands and time needed to set up recording equipment, the impact on the session and the therapeutic process with the addition of a camera, but most of all because of the additional time required to go back and analyse recorded data. That said, it is possible for therapists who might be fortunate to have equipment and time to use it and a practice context that enables time spent post-session on assessment to record sessions and assess participants' progress in them in the same way as they might in sessions. Advantages of post-session assessment include the full focus a therapist can give to assessment, when not also trying to hold the space and lead activities, and the possibility of discussion with other colleagues together in the observation and analysis process. Disadvantages of post-session assessment using recordings include the limitations of recording for capturing all that is happening in a session, especially of group sessions.

How many objectives to assess?

We recommend that therapists select a small number of objectives to assess against, even if they believe the likely possibility that their program addresses many of the outcomes outlined in the *Framework*. Our previous experience indicates that when working with groups, a maximum of two specific objectives is more than enough for a therapist to manage in any one period (Dunphy & Hens, 2018).

Our experience is also that these objectives need to be the same for all members of the group for assessment to be manageable. This doesn't mean that individual participants do not have different needs, but that for assessment purposes in a typical DMT context with high demands and low support, a manageable demand on the therapist is recommended. Our experience has also been that the more demanding the assessment task is, the less likely to therapist is to sustain regular assessment practices. This system has been invented to support therapists to undertake regular, systematic assessment within the significant limits of most current DMT workplaces.

These choices depend on the specific situation. If the therapist is well supported with skilled program staff and has paid time to spend on assessing and writing up notes and reporting on participants' progress, then s/he might be able to assess against more items. For therapists working one on one with participants, it might be feasible to assess a wider range of objectives.

What is the minimum number of sessions needed before the therapist can undertake valid assessment?

We have found it helpful to have at least two sessions with participants before expecting to be able to assess them. We recommend having some familiarity with the *Framework* and some practice navigating *MARA* before attempting to use them in sessions.

Scoring of objectives that have a range, such as Effort elements

The idea of the reporting using the *Framework* for any element, such as Time, is that you are looking for clients' increased access to that whole element, across its range. For example, for the Effort quality of Time, a DM therapist would ideally support their participant to achieve the fullest access to the spectrum of Suddenness to Sustainment, with neither extreme being better or worse. What is desirable is that participants have access to both extremes or polarities of the element.

Therefore, good access across the range (within the participant's capabilities) would score highly. Where a participant was not demonstrating good access to one or other aspect of Time (suddenness or sustainment, or the whole spectrum), again as relative to their capability, then they might also score lower.

If a therapist decides to work with a participant on one aspect of Time, such as suddenness, because the participant had little access to that, the participant might first be scored low on that element, and the therapist would write in their accompanying that their score was related to Suddenness. There might not be a focus on sustainment in that session because the participant had good access to it, or because the participant and therapist had decided to work on the different polarities of Time separately. If you were working on sustainment in a different session, the score might be either high or low depending on what you observed, and your notes would help support your scores.

The scoring has been created like this so that scores increasing from low to high indicate improvement- with high scores indicating fuller access to the range of polarities for any element, for example. If each element was scored separately, this is not necessarily so: a participant's access to suddenness is only really desirable if they also have access to sustainment. A high score on suddenness with a low score on sustainment might not be a desirable outcome for a participant. The goal of therapy, eventually, is higher scores on every element.

How can the therapist's judgement be valid given that it is subjective?

The issue of subjectivity in assessment is a tricky one, but no more so for using the *Framework* than any other assessment tool in DMT. However, the *Framework* has been developed as a tool for trained DMT professionals who are bringing their skilled judgement, expert 'eyes' and knowledge of their own participants and/ or participant groups to the assessment task. This underpins all assessment scoring. That is why we are with our participants, because our training and experience enables us to make judgements based on our observations. We do this to make decisions for our practice, of assessment is a critical aspect.

Our own experience in informal testing with assessment scoring using the *Framework* in *MARA* so far is that consistency between scorers is remarkably high, even when scoring is being done by people who know and don't know the participant, and who have different training (DMT and non-DMT). We have written about this a bit in our article (Dunphy & Hens, 2018).

Inter-rater reliability scores (the extent to which two or more raters agree) in the first formally reported trial were moderate to good (Dunphy & Hens, 2018), even for scorers assessing at different times (during and after the session).

This offers support for the reliability of *MARA* as an assessment tool. Trials are continuing to formally test the validity and reliability of the *Outcomes Framework*.

The additional modalities of notes, photos, videos, drawings and audio recordings that *MARA* facilitates also strengthen therapists' assessment judgement as they provide triangulation of numerical data.

Other potential contributors to assessment

In addition to the assessment led by the therapist, the Framework also offers the possibility of other stakeholders contributing to the assessment process.

Self-assessment by participant

One possibility offered by the *Framework* is that participants contribute to the assessment process. This offers empowerment to participants in recognising them as experts in their own lives. Participants' contribution in self-assessment and feedback in therapy has also been shown to boost consistent attendance at sessions, support participants' self-awareness and contribute to therapist's capacity.

The participant might assess their own progress, possibly utilising the short version of the *Framework* that is less complex and therefore easier to understand and navigate. They might use numerical scoring or offer a verbal reflection that might be assigned a numerical score by the therapist. For example, if the participant commented 'heavenly' about an experience, we could score this as high on 3.1.3 'fun, pleasure and enjoyment', whereas a comment like 'boring' would be assessed as much lower on the same objective. It is also possible for an embodied response to be given a numerical rating, offering those without verbal communication skills the opportunity for self-assessment as well. *MARA*'s media options also make assessment contribution more accessible, for participants who may not be literate or numerate or have access to verbal language skills.

Participants may be invited to offer a media response, photo, video or voice recording, or arts-based response including drawing. Participants may also be invited to engage in a process of self-reflection and assessment, from baseline, assessing 'My current state- how I see myself on this item' to target, 'where I would like to get to?' and progress 'what did I get to at this moment?'.

Other stakeholders

Other assessment possibilities include the contribution of other stakeholders who might not be trained in DMT. The *Framework* prioritises the use of lay language, and minimizes specialist jargon, except in the use of LBMS measures in the Physical domain to facilitate the possibility that the *Framework* could be used by other stakeholders in the therapeutic process. Other professionals can contribute to assessment within their areas of expertise. Often they will have a broader experience with participants than DM therapists, as they are likely to have more contact over longer periods of time and contexts. A previous study on the *Framework* and *MARA* indicated that different stakeholders in the therapeutic process, including DM students, school leaders and education assistants, reported finding these tools useful in setting and assessing participants' progress against program objectives (Dunphy, Mullane & Allen, 2016).

Families and carers may also be engaged in the assessment process to some degree, either contributing information themselves in response to assessment data that is shared or to reports. Their observation or insight may be a valuable complement to the DM therapists' (Dunphy, Mullane & Allen, 2016; Hens & Dunphy, 2018). A previous study found that disability service agency managers, staff, families, carers and participants themselves found reports created from data generated by these tools to be useful and relevant (Dunphy & Hens, 2018).

Between session engagement

The Framework and *MARA* can also support in between session engagement, with participants encouraged through homework tasks to reflect on their own progress. This might include taking a photo or video or drawing or journaling that can be sent to the therapist and uploaded into *MARA*. Participants' input or homework can be shared between participant and therapist at the start of session to help shape the session objectives or content.

Individual and group profiles

A profile is a snapshot of the assessment scores of a participant or group at a given point in time, enabling determination of their strengths and areas for potential improvement or development. The content of the profile is decided by the therapist and participant(s). It may be taken using their entire *Framework* or selected objectives that may be specific priorities. This would be done by assessing participant/s on objectives that might be considered relevant, perhaps from the host organisation's goals, the therapist's own perspective, participants' expressed interests or concerns, or other reasons. A therapist may then decide to focus in the therapy sessions on objectives that participants' scores indicated strength on, or those which needed development, or a combination of the two.

A group profile allows an overview of the specific group strengths according to the domains, sub-domains and items in the *Framework*, indicating the homogeneity or diversity of strengths and needs of the participants as a whole. Therapists can identify achievement levels present in the group, by utilising data such as mean, standard deviation and median scores and percentages in each possible scoring. The therapist can look for extreme results (minimum, maximum

scoring values) in order to identify strengths and create group activities or define sub-groups according to their needs (possibly setting sub-group where some participants are supporting or modelling other participants in this group). Looking at these overall results, high or low scoring values, will inform planning to accommodate goal priorities and specific strategies. An additional use of a group profile is the possibility to inform and report agencies who fund the program in a brief and clear way.

This group profile does not exclude the need for individual and participant-centred therapy, and the therapist should always make sure the group profile should not be used for discriminatory, social sorting and segmentation of individuals.

The tables to follow offer examples of group profiles created from scoring using the *Framework* entered into the Excel worksheets (available <https://www.makingdancematter.com.au/resources/>)

Assessing a group: can a group be scored as a whole?

Both the *Framework* Excel sheet and *MARA* offer the possibility of having data about the group as a whole, as they calculate graphs for individuals and the group.

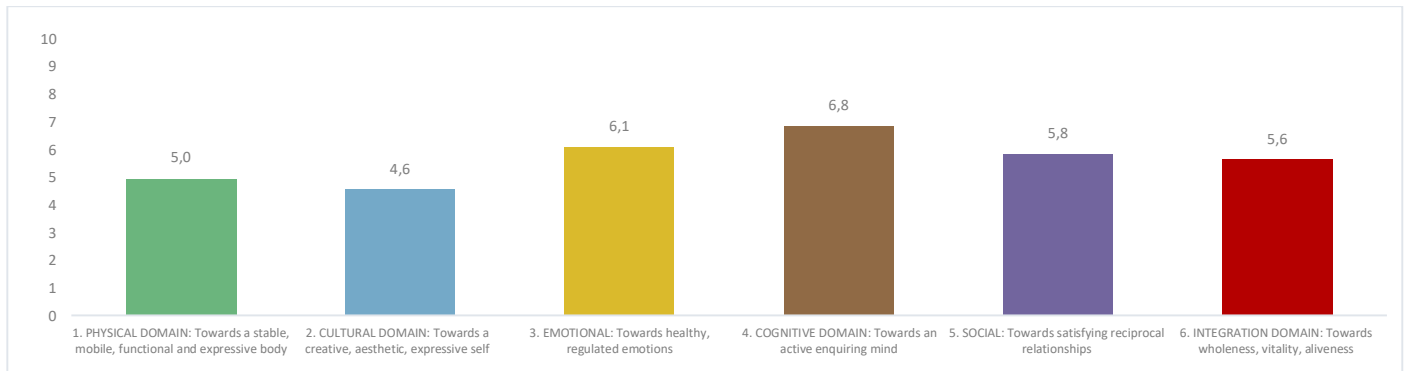

Figure 1 Group profile: mean score per domain

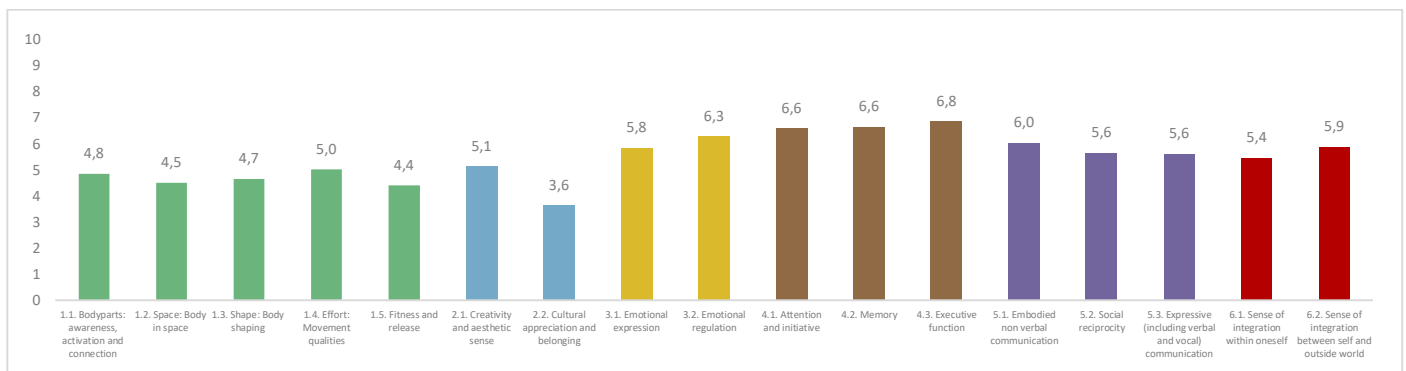

Figure 2 Group profile: mean score per sub-domain

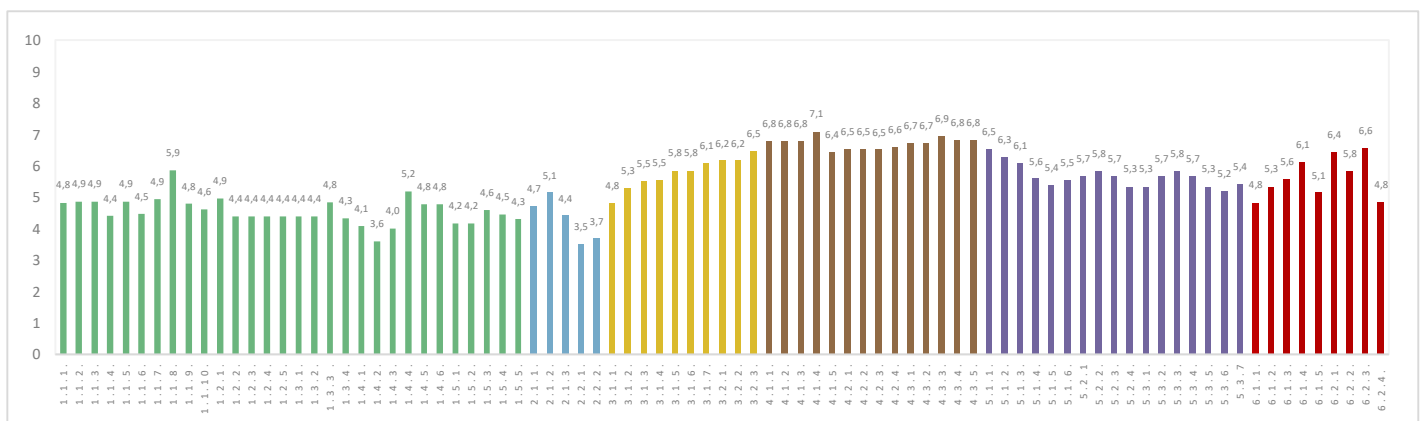

Figure 3 Group profile: Mean score per item (objective)

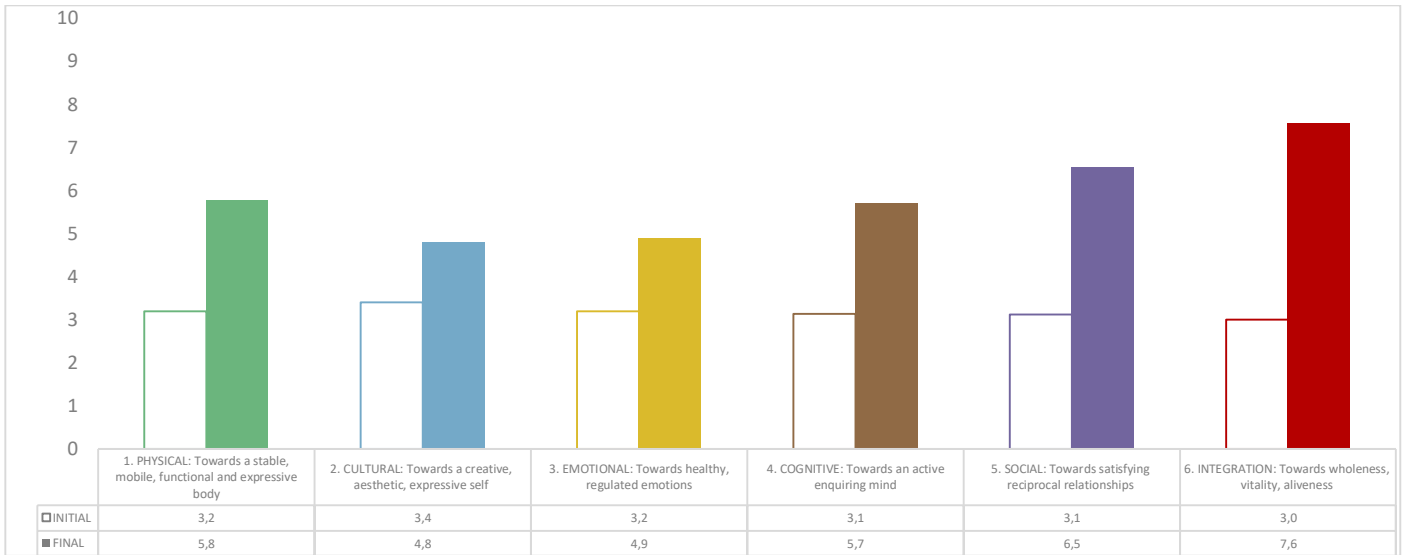

Figure 4 Group profile: Mean score per domain: initial and final assessment

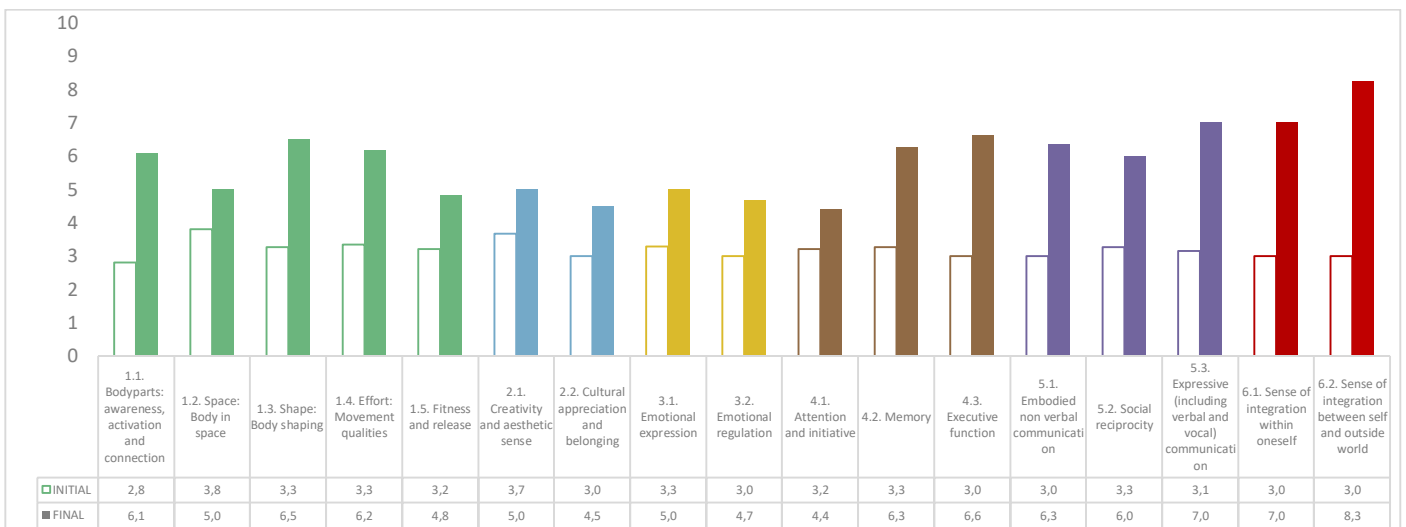

Figure 5 Group profile: Mean score per sub-domain: initial and final assessment

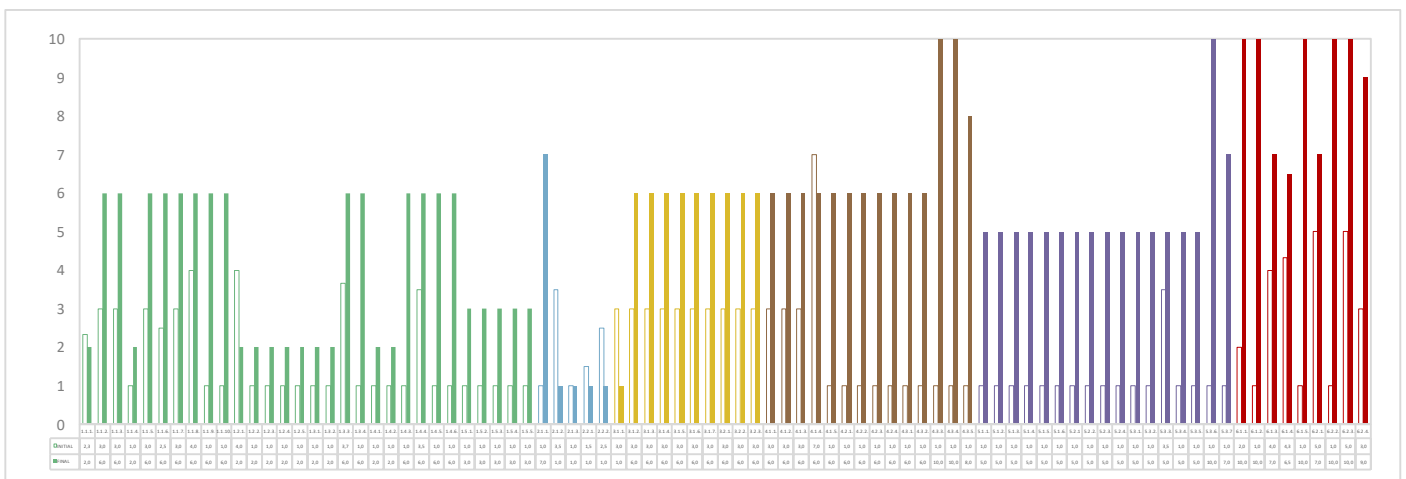

Figure 6 Group profile: Mean score per item (objective): initial and final assessment

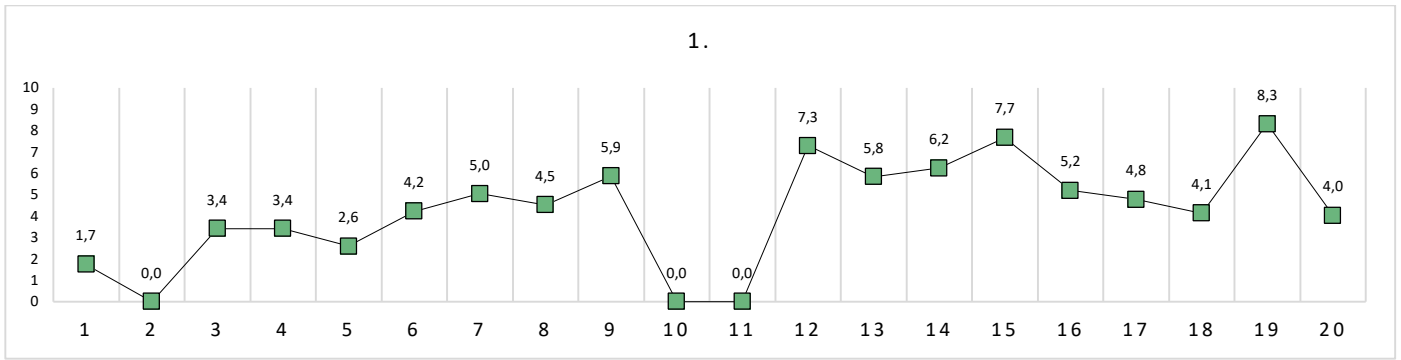

Figure 7 Group profile: Mean scores per domain per session

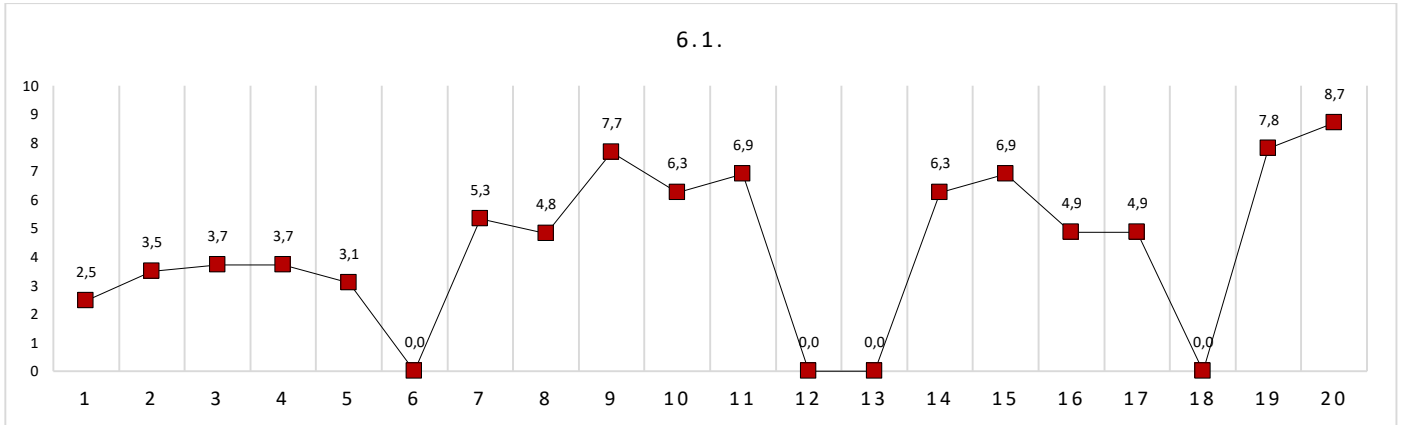

Figure 8 Group profile: Mean scores per sub-domain per session

SESSION NUMBER	1	2	3	4	5	6	7	8	9	10	11	12	13	14	15	16	17	18	19	20	Number of sessions with scoring	Overall mean across sessions	Standard deviation	Minimum value	Maximum value	Median (percentile 50%)	
SUB-DOMAIN /DOMAIN																											
1.1. Body parts: awareness, activation and connection	2,4	-	3,8	3,8	3,2	4,4	5,1	4,4	5,7	-	-	7,0	5,7	6,2	-	-	4,2	4,0	7,6	5,2	15,0	4,8	1,4	2,4	7,6	4,4	
1.2. Space: Body in space	1,6	-	3,3	3,3	2,5	4,2	5,1	4,2	5,9	-	-	7,7	5,9	-	-	-	-	4,2	8,5	2,0	13,0	4,5	2,1	1,6	8,5	4,2	
1.3. Shape: Body shaping	1,7	-	3,3	3,3	2,5	4,2	5,0	4,2	5,8	-	-	7,5	5,8	-	-	-	-	4,2	9,0	4,0	13,0	4,7	2,0	1,7	9,0	4,2	
1.4. Effort: Movement qualities	1,4	-	3,3	3,3	2,3	4,2	5,1	4,2	6,0	-	-	8,0	6,0	-	7,7	5,0	-	5,0	9,0	4,7	15,0	5,0	2,1	1,4	9,0	5,0	
1.5. Fitness and release	1,0	-	3,0	3,0	2,0	4,0	5,0	5,8	6,0	-	-	-	-	-	-	5,3	5,5	-	9,0	3,0	12,0	4,4	2,2	1,0	9,0	4,5	
2.1. Creativity and aesthetic sense	1,8	6,0	3,5	3,5	5,3	4,3	5,2	7,0	6,0	6,8	-	-	-	-	-	-	-	-	9,0	3,0	12,0	5,1	2,0	1,8	9,0	5,3	
2.2. Cultural appreciation and belonging	2,0	2,0	2,5	2,5	7,0	3,0	3,5	7,0	4,0	4,5	-	-	-	4,5	-	-	-	-	-	-	1,0	12,0	3,6	1,9	1,0	7,0	3,3
3.1. Emotional expression	3,0	-	3,0	3,0	7,0	4,4	6,0	7,0	6,7	7,0	8,0	-	-	7,0	-	7,0	-	7,0	-	5,3	14,0	5,8	1,8	3,0	8,0	6,9	
3.2. Emotional regulation	3,0	-	4,3	3,0	7,0	7,0	7,0	-	7,0	7,0	8,0	8,0	-	-	-	7,0	-	7,0	-	6,0	13,0	6,3	1,7	3,0	8,0	7,0	
4.1. Attention and initiative	3,4	-	7,0	7,0	7,0	7,0	7,0	4,0	7,0	7,0	8,0	8,0	6,0	-	-	7,0	-	7,2	-	6,0	15,0	6,6	1,3	3,4	8,0	7,0	
4.2. Memory	1,0	-	7,0	7,0	7,0	7,0	7,0	4,0	7,0	7,0	8,0	8,0	6,0	-	8,0	-	8,0	8,0	-	6,0	16,0	6,6	1,8	1,0	8,0	7,0	
4.3. Executive function	1,0	-	7,0	7,0	7,0	5,2	-	4,0	-	7,0	8,0	8,0	6,0	-	8,0	-	9,0	9,0	8,3	8,0	15,0	6,8	2,1	1,0	9,0	7,0	
5.1. Embodied non-verbal communication	1,0	-	3,0	3,7	7,0	7,0	-	4,0	6,0	7,0	8,0	8,0	6,0	-	8,0	-	7,0	7,0	8,7	5,0	16,0	6,0	2,1	1,0	8,7	7,0	
5.2. Social reciprocity	1,0	-	3,0	3,0	-	7,0	-	-	-	7,0	8,0	-	-	7,0	8,0	-	4,8	4,8	9,0	5,0	12,0	5,6	2,4	1,0	9,0	6,0	
5.3. Expressive (including verbal and vocal) communication	1,4	6,0	3,2	3,2	6,0	6,4	-	6,0	-	6,9	7,9	-	-	6,5	7,9	4,2	4,2	-	8,2	6,0	15,0	5,6	2,0	1,4	8,2	6,0	
6.1. Sense of integration within oneself	2,5	3,5	3,7	3,7	3,1	-	5,3	4,8	7,7	6,3	6,9	-	-	6,3	6,9	4,9	4,9	-	7,8	8,7	16,0	5,4	1,9	2,5	8,7	5,1	
6.2. Sense of integration between self and outside world	3,5	4,0	4,5	4,5	4,0	-	5,5	5,7	6,0	6,5	7,0	-	5,8	6,5	7,0	6,8	6,8	5,7	7,0	9,0	18,0	5,9	1,4	3,5	9,0	5,9	
1. PHYSICAL: Towards a stable, mobile, functional and expressive body	1,7	-	3,4	3,4	2,6	4,2	5,0	4,5	5,9	-	-	7,3	5,8	6,2	7,7	5,2	4,8	4,1	8,3	4,0	17,0	5,0	1,8	1,7	8,3	4,8	
2. CULTURAL: Towards a creative, aesthetic, expressive self	1,9	3,3	3,1	3,1	6,0	3,8	4,5	7,0	5,2	5,6	-	-	-	4,5	-	-	-	-	9,0	2,2	13,0	4,6	2,0	1,9	9,0	4,5	
3. EMOTIONAL: Towards healthy, regulated emotions	3,0	-	3,4	3,0	7,0	5,2	6,3	7,0	6,8	7,0	8,0	8,0	-	7,0	-	7,0	-	7,0	-	5,5	15,0	6,1	1,7	3,0	8,0	7,0	
4. COGNITIVE: Towards an active enquiring mind	1,9	-	7,0	7,0	7,0	6,4	7,0	4,0	7,0	7,0	8,0	8,0	6,0	-	8,0	7,0	8,8	8,1	8,3	6,7	18,0	6,8	1,6	1,9	8,8	7,0	
SOCIAL: Towards satisfying reciprocal relationships	1,1	6,0	3,1	3,3	6,7	6,8	-	4,5	6,0	7,0	7,9	8,0	6,0	6,7	7,9	4,2	5,3	6,1	8,6	5,4	19,0	5,8	1,9	1,1	8,6	6,0	
6. INTEGRATION: Towards wholeness, vitality, aliveness	2,9	3,8	4,1	4,1	3,5	-	5,4	5,3	6,7	6,4	6,9	-	5,8	6,4	6,9	5,7	5,7	5,7	7,4	8,8	18,0	5,6	1,5	2,9	8,8	5,7	

Table 3 Group profile: mean scores per session, number of sessions scored, mean, standard deviation, minimum value (lowest score, maximum value (highest) score, median percentile 50%, for sub-domains and domains.

ABOUT THE PHYSICAL DOMAIN

Towards a stable, mobile, functional and expressive body

The Physical domain is the first and major focus for dance movement therapy, with endpoint of stable, mobile, functional and expressive body. This comprises four aspects, of stability and mobility required by the body and functionality and expressivity that make up movement.

This domain is informed significantly by the work of movement theorists Laban (2011), Bartenieff (1980), Hackney (2002) and Bainbridge Cohen (2018). It is underpinned by theoretical constructs drawing from the LBMS (Laban Bartenieff Movement System) which incorporates the Body and Bartenieff Fundamentals and Space Harmony across four major elements: BESS; Body, Efforts, Shape and Space. Its five sub-domains are 1.1 Body parts: awareness, activation, connection; 1.2 Space: Body in space; 1.3 Shape: Body shaping; 1.4 Efforts: movement qualities; and 1.5 Fitness and release.

Body describes the structural and physical characteristics of the human body while moving, including which body parts are moving, which parts are connected, which parts are influenced by others, and general statements about body organization. *Shape* is the way the body changes shape during movement and an integrating factor for combining the categories into meaningful movement. *Space* is about how the person utilises the space around them, involving motion in connection with the environment, and with spatial patterns, pathways, and lines of spatial tension. *Efforts* is a system for understanding the more subtle characteristics about movement with respect to the quality of movement, and particularly how it reflects the inner intention of the mover. It has four subcategories (Effort factors: Flow, Weight, Space and Time), each of which has two opposite polarities (Effort elements). The *Efforts* offer a bridge to the invariants of the psychological self, identified by psychotherapy theory: agency, vitality, cohesion and continuity (Lauffenburger, 2020).

The LMBS system is based on themes of opposites: Mobility and Stability, which work together to provide different body supports and actions; Inner and Outer; Function and Expression, which have an interdependency; and Exertion and Recuperation, which is a natural process for those with efficient movement (Bartenieff, 1980). This domain is also informed by Developmental Movement Patterns conceptualised by Bainbridge Cohen, of yield, push, reach, grasp, pull and release, which have largely been collapsed into six patterns in LBMS. In developmental order these are: Breath, Core-Distal, Head-Tail, Upper-Lower, Body-Half and Cross-Laterality (Bainbridge Cohen, 2019).

Although movement assessment tools are used in other professions, these generally focus on functional rather than expressive aspects of movement. The concepts discussed here can be used to illuminate the connection between body and mind. They enable the observed expressive components of movement to inform analysis of subjective experience as well as a nuanced view of the inner life of the participant (Bartenieff & Lewis, 1980). For example, body awareness is also seen as the basis for emotional regulation and expression of emotional states to others (Homann, 2010). Development of body awareness through DMT has a neurological effect on our brains, including initiating a down-regulation of the nervous system, which makes us feel calm, while increasing awareness of emotional states through awareness of body states helps us to make choices in relation to how we express (Homann, 2010).

This system does not prioritise or preference any one movement or aspect of movement over others but identifies the full range of options for the human body and function. The greater access or range that a person has in movement, and the more options they have to bring those options into their life at the appropriate moment, the greater their adaptability will be. For example, in the Effort domain, the Effort factors of Weight with its polarities of Strength and Lightness are both equally necessary: for example, for the strength to hold a baby safely and for the lightness to soothe and stroke it; while the Effort factors of Time has both sustainment, that we might need to hold a full drink steady as we carry it and suddenness to respond quickly to catch the cup if we were to trip and drop it. DMT activities work to expand the movement repertoire and on missed or inappropriately established developmental steps by providing the person with a space to practice or relearn those steps (Koch, 2019).

Fitness and release

This domain also includes sub-domain of Fitness and Release which includes objectives of stamina, strength, flexibility, balance and release of physical tension, which are outside the parameters of the LMBS. The first four are more commonly used in other movement and fitness assessment approaches. They are presented here with the assumption that they will be assessed by the therapist using their professional judgement, with no requirement of specialist equipment or apparatus that might be required in other approaches to fitness testing. Release of physical tension is a significant and relevant possibility for dance movement therapy.

Empirical evidence for the contribution of dance and dance movement therapy in this domain includes outcomes of; improved posture, balance, co-ordination, fitness levels and reduced stress (Burzynska, Fine, Taylor Knecht & Kramer, 2017; Lee, 1999); improvement of motor function by training muscular activity, balance and flexibility (Koch et al, 2019); tension relieved by use of relaxation exercises (Koch, 2019).

For specific client groups, outcomes include: for patients who have experienced trauma, increased sense of wellbeing and experienced health and reduced pain levels through flamenco therapy (Koch et al, 2019); for patients with Parkinson’s disease, improvements in motor function and balance (De Dreu 2012, Kiepe et al., 2012; Hackney & Bennett, 2014; Sharp & Hewitt, 2014; Loetzke, 2015; Shanahan et al, 2015; Aguiar et al, 2016; de Natale, et al, 2017); for people with medical conditions, improved physiological markers such as blood pressure and exercise capacity (Conceicao et al 2016, Gomes Neto et al 2014, Kiepe et al, 2012 Rodrigues-Krause et al, 2016); for patients with schizophrenia, overcoming of feelings of disembodiment (Martin, Koch, Hirjak & Fuchs, 2016); for persons with rheumatoid arthritis, improved physical fitness (Noreau et al, 1995); and in the elderly, improved flexibility and muscle strength of lower limbs (Lee, 1999).

OUTCOME DOMAIN 1  1. Physical Domain TOWARDS A STABLE, MOBILE, FUNCTIONAL AND EXPRESSIVE BODY	PHYSICAL: TOWARDS A STABLE, MOBILE, FUNCTIONAL & EXPRESSIVE BODY
--	---

SUB-DOMAIN & OBJECTIVES	DEFINITION OF OUTCOME
-------------------------	-----------------------

1.1  Body parts: awareness, activation, connection	<i>What is moving: which body parts are moving and the way these work together in movement: involving capacity for awareness, activation and connection of the body and breath, and sequencing and integration of movement.</i>
1.1.1	Use of breath to support movement Activation and control of breath to support movement, including depth, rate and shape of breath.
1.1.2	Activation of body parts: upper, lower body Awareness of body parts demonstrated through activation and or naming of body parts: upper (head, shoulders, upper torso, arms, hands); lower (lower torso, legs, knees, ankles, feet).
1.1.3	Activation of body hemispheres: left, right Awareness of body hemispheres demonstrated through activation and or naming of left and right hemispheres.
1.1.4	Body parts connection: centre to extremities, head to tail connections Awareness of, and connections demonstrated between: core (centre) of the body and distal (extremities, hands, feet and tail); head and tail (base of spine, coccyx).
1.1.5	Body parts connection: upper and lower body Awareness of and connections demonstrated between: upper and lower halves of the body (homologous) mostly involving limbs. Upper body functions for mobility and articulation, while lower body functions for stability and locomotion.
1.1.6	Body halves connection: right and left sides Activation of and connections demonstrated between: right and left sides of the body (homolateral) where one side of the body is stabilised while the other mobilises. Movement can switch from one side to the other but does not cross the midline.
1.1.7	Body parts connection: diagonal movement Connection of the body diagonally (top-left to bottom-right, etc), moving one upper limb with the opposite lower limb; cross the midline of the body with any body part. This includes diagonal movement such as creeping on hands and forelegs, walking, running and leaping.
1.1.8	Sequencing of body parts in movement Sequencing of body parts for effective movement, including simultaneous (at the same time), successive (one and then another), or sequential (one followed by another, flowing from one movement to another) sequencing.
1.1.9	Self-synchrony: body parts moving in rhythm with oneself Movement of body parts in an integrated and organised way, in synchrony, with timing of movement distributed through the body.

1.1.10	Control of movement succession	Control of movement succession: including initiation (beginning movement); sustainment (holding movement); conclusion (stopping movement); release (letting go of partner, prop, action).
--------	---------------------------------------	---

	Space: Body in space	Where the body moves: involving the use of direction of a movement (up/down, forward/backward, sideways or across), and planes the movement occurs in (vertical, sagittal, horizontal), and use of the kinaesphere (e.g. near - far reach space).
1.2.1	Kinaesphere: access to near-, mid- and far- reach space	Access to movement across the full kinaesphere, (the three-dimensional volume of space that can be accessed without a shift of weight to change one's stance), encompassing near reach (close to ourselves), mid reach (in between), far reach (large movements) in space. It also incorporates the area that the body is moving within and the way the mover is paying attention to it.
1.2.2	Movement planes: access to vertical, horizontal, sagittal planes	Access to movement within and across planes, vertical (up and down), horizontal (around the central axis), sagittal (forwards and backwards); make transition/s from plane to plane; access movement pathways: peripheral (passing between the centre of the body and the periphery of the kinaesphere); central (initiated from or passing through the centre of the body), or transversal (passing between the centre of the body and the periphery of the kinaesphere).
1.2.3	Spatial intention: mover identifies and uses directions or points in space	Identification and movement towards directions or points in space.
1.2.4	Levels in space: access to low, medium, high levels	Access to different levels (high, medium and low) and locations in space.
1.2.5	Managing body boundaries in space	Movement of body that is appropriate within the confines of that space, involving proprioceptive sense, manoeuvring objects and areas in space.

	Shape: Body shaping	The why of movement: involving the capacity for change in the shape of the body itself, moving in relation to one's surroundings, to others and to one's own needs; the capacity for the body to enclose or spread, rise or sink.
1.3.1	Shape Flow: access to Shape Flow, representing a relationship of the body to itself	Body-oriented shaping, representing a relationship of the body to itself, including growing and shrinking movements across the planes: vertical (lengthening/shortening); horizontal (widening/narrowing); and sagittal (bulging/hollowing). This could be amoebic like-movement or usual actions, like shrugging, shivering, rubbing an injured shoulder.
1.3.2	Directional: access to Directional Shaping of the body	Body direction towards some part of the environment, making goal-oriented movements such as reaching to touch something, in either spoke-like (such as punching and pointing) and arc-like (swinging a tennis racket, painting a fence) movements.
1.3.3	Carving: access to Space Carving, the body's active and three-dimensional interaction with the volume of the environment	The body's active and three-dimensional interaction with the volume of the environment, in a quality of movement that leads to integration of the self and the world. Evidenced in tasks like kneading bread dough, wringing out a towel or miming the shape of an imaginary object.
1.3.4	Shape qualities: access to Shape qualities, opening and closing	The body's change in an active way toward some point in space, either opening (growing larger with more extension) or closing (growing smaller with more flexion), including actions of rising, sinking, spreading, enclosing, advancing and retreating. Environment-oriented shape that includes carving, moulding and sculpting.

	Effort: Movement qualities	How the body moves in terms of qualities of movement, reflecting the mover's intention or inner attitude towards movement, manifested in access to four movement factors, Weight, Space, Time, Flow, each of which spans two opposite poles.
1.4.1	Weight: access to Active (light - strong) and	Access to force in movement, through sensing, intention, feeling one's own weight, presence and relationship to earth/gravity, across the

	Passive (limp - heavy) Weight Efforts	continuums of movement of <i>Light</i> (delicate, fragile, overcoming one's weight, buoyant, lifted up) to <i>Strong</i> (power, standing one's ground, immovable); and <i>Limp</i> (giving up my weight) to <i>Heavy</i> (complete collapse).
1.4.2	Space: access to Direct – Indirect Space Efforts	Use of direction or focus of movement across the continuums from <i>Indirect</i> : Multi-focused, overlapping, roundabout, taking it all in, expansive, seeing all possibilities, to <i>Direct</i> : channelled, honing in, riveted, linear, laser-like, single-focused, pin- pointed, this is the way. It is about thinking, attention, intellect and ideas, perception - using the senses, environment/other related, external.
1.4.3	Time: access to Sudden – Sustained Time Efforts	Access to acceleration and deceleration of movement, across the continuum of <i>Sustained</i> (drawing out the moment, luxuriate, languidly, adagio, prolonging, leisurely) to <i>Sudden</i> (urgent, instantaneous, staccato, quick, hurried, spark like) movement. It is about intuition, decision-making, related to the moment, now versus not now, knowing the right moment to act.
1.4.4	Flow: Access to Bound - Free Flow Efforts	Control of the progression of movement across the continuum of <i>Bound</i> (contained, controlled, keeping the inside in and the outside out, can be stopped at any moment, rigid, boundaries, clarity) to <i>Free</i> (outpouring, letting the inside out and the outside in, uncontrollable, open-hearted, fluid) movement. Flow is about continuity, progression, emotions, involvement and is responsible for the ongoingness of movement.
1.4.5	Effort combinations: access to combinations of Effort elements	Activation and integration of two or more Effort elements simultaneously, with the combinations of two efforts known as states being: Awake - Space and Time; Dreamlike - Weight and Flow; Distant - Space and Flow; Near/Rhythm - Time and Weight; Stable - Space and Weight. Combinations of three efforts (Drives) are: Action Drive - Weight, Space and Time without Flow; Passion Drive –Weight, Time and Flow without Space; Spell Drive – Weight, Space and Flow without Time; Vision Drive – Space, Time and Flow without Weight.
1.4.6	Effort phrasing: access to Effort phrasing	Capacity to access the coming and going of Effort qualities: ebb and flow of movement.

1.5	Fitness and release	The state of being physically fit and healthy; the capacity to carry out daily tasks with vigour and alertness, without undue fatigue; and the capacity to release tension.
		
1.5.1	Stamina	Sustainment of prolonged physical effort, including aerobic fitness.
1.5.2	Strength	State of being physically strong, including the ability to exert force on objects or exert one's sense of self in space.
1.5.3	Flexibility	Free movement of joints across a range of motion and mobility of muscles that allows freedom of movement around joints.
1.5.4	Balance	Even distribution of weight, capacity to remain upright, steady, both static (in stillness) and dynamic (in movement).
1.5.5	Release of physical tension	Capacity to achieve a state of physical relaxation, through tension and relaxing of different sets of muscles, as evidenced in relaxed stillness; quieting of extraneous vocal communication or embodied movement, access to deep, slow regulated breathing; or in movement, as evidenced in overall sense of comfort and ease and impression of being fully present in the body.

ABOUT THE CULTURAL DOMAIN

Towards a creative, aesthetic, expressive self

The Cultural is the domain of creation, generativity, aesthetic enrichment and expression. While the word *culture* has a spectrum of meanings, ranging from the anthropological (as a way of life) to the sociological (how we do things), in this context it is considered as the ability to categorize and represent experiences with symbols and to act imaginatively and creatively through artistic practices. It also relates to the broader definition offered by UNESCO which includes 'the set of distinctive spiritual, material, intellectual and emotional features of society or a social group, that encompasses, not only art and literature, but lifestyles, ways of living together, value systems, traditions and beliefs' (UNESCO, 2001).

In this Framework, the domain's endpoint is of a *creative, aesthetic, expressive* self, with *creative* being the generative, productive aspect of being, *aesthetic* defined as experiences of the senses, in any or all of the sensory domains (Schifferstein & Hekkert, 2013; Shimamura, 2014) that can be catalysed by an object or any other stimulus, including abstract ideas (Hekkert, 2014). While aesthetic is sometimes considered related to experiences of *beauty* and *pleasure*, in this *Framework*, a wider perspective of aesthetic *enrichment* is considered, with *enrichment* understood as a process that makes an experience more significant, meaningful or valuable. It refers to the more frequently expected pleasurable emotions of joy, wonder and awe (Keltner & Haidt, 2003) arising from perceptions of beauty, but also incorporates the full breadth of emotional and cognitive experiences that are evoked through perceiving and processing artistic experiences. These might range from awe and fascination to bewilderment and sadness (Frijda, 1989). These experiences of aesthetic enrichment can be as trivial as a sense of escape from daily life or captivation in the moment, to deeper feelings of being moved or intensely engaged. They also extend to the most profound experiences of flow state (Csikszentmihalyi, 1990), transcendence or access to the other-worldly realms of the numinous or spiritual. Aesthetic enrichment can result from participation in cultural experiences that are familiar, a process described as aesthetic validation, or unfamiliar; also described as aesthetic growth or challenge (Brown & Novak-Leonard, 2013; Hekkert, et al., 2003). Pleasure arises from the reward stimulated by new experiences and solving of dilemmas or challenges through contemplation (Armstrong and Detweiler-Bedell, 2008). Finally, *expressive* is considered as actions of communications that show feelings and are imbued with meaning.

The domain comprises two sub-domains of: *Creativity and aesthetic sense* and *Cultural appreciation and belonging*, informed by Dunphy et al's (2020) schema of outcomes of cultural engagement. *Cultural appreciation* is defined as the enjoyment, celebration or treasuring of the value and quality of different forms of cultural expression that can be elicited in the therapeutic process, and *cultural expression* understood as the different ways that people express themselves depending on their cultural backgrounds, life experience and interests. Thus, forms of cultural expression might be related to ethnic, linguistic, religious or national heritage, but also in identification with others who share expressive interests. This might include the affiliation of people who have a common experience of disability that they seek to express, or expertise in a particular type of cultural expression, such as spoken word, Bharatnatyam dance, hiphop or oil painting. Cultural belonging is considered as meaning a sense of fitting in or feeling like one is an important member of a group, having a sense of relationship to one's experience of cultural identity and values shared with others that can be deepened by in the creative therapeutic process. This includes a deeper connection to a cultural heritage, the 'expression of the ways of living, developed by a community and passed on from generation to generation' (ICOMOS, 2005). This sense of belonging is seen to be significant because it contributes to the meaning people make of their lives: the greater a sense of belonging, the greater the meaning promoted (Lambert et al., 2013).

This domain is fundamental to all creative arts therapies because of their basic premise of engagement with creativity and the aesthetic expressive self (Jones, 2020) and the understanding that all people hold within themselves creative potential. Creativity is the process by which the participant explores personal meaning, sense of self and unique relational experiences (Lauffenburger, 2020). This is critical within the therapeutic relationship as it provides the foundation of the intersubjective therapeutic collaboration (Wengrower, 2016; Lauffenburger, 2020). The expressive product created in the therapeutic experience supplies important messages to the individual (Rogers, 2016, p. 246).

However, it is most often articulated only as a process, rather than also an outcome, for example, as Koch (2017) identifies aesthetic experience (experiencing beauty, mind-body unity) and creation, such as generativity and productivity as active factors of these modalities. Assessment instruments offer few options for measurement of these experiences as outcomes.

Nevertheless, some indication of creativity and expression as intentions are offered in the literature. Samaritter articulates how the patient's potential for sensing, articulating and expressing, for being an agent and a maker can develop through arts therapies as the process of (co-)creation within the arts modality stimulates the emergence, deepening or fluctuation of aesthetic engagement (2018). The aesthetic unfolding happens when an individual is simultaneously engaged in inward deepening of lived experiences and outward appreciation of and assignment of meaning to a phenomenon or event (Samaritter, 2018, 3 [19]). McNiff posits development of aesthetic sensibilities that

can occur through art therapy such as changes in the content and quality of artistic expression, increased spontaneity, greater persistence in the making of art, and fluctuations in the aesthetic satisfaction of both participant and therapist (1998, 203).

Empirical support for the outcomes of this domain include, with respect to sub-domain 2.1 *Creativity and aesthetic sense*, aesthetic, that tango dance used in DMT elicited a sense of beauty and aesthetic pleasure for Parkinson's patients (Koch, 2016); and for sub-domain 2.2 *Cultural appreciation and belonging*, that non-verbal expressive art served as a form of metaphor for communication between women of different cultural groups (Jewish/ Israeli and Arab/ Palestinian women), offering them another perspective from which to perceive each other (Rogers, 2016); and that dance techniques, including circle dances, provide cultural references and possibilities for ritualised use (Koch, 2019).

<p>OUTCOME DOMAIN 2</p>  <p>2. Cultural Domain TOWARDS A CREATIVE, AESTHETIC, EXPRESSIVE SELF</p>	<p>CULTURAL: TOWARDS A CREATIVE, AESTHETIC, EXPRESSIVE SELF</p>
--	--

SUB-DOMAIN & OBJECTIVES	DEFINITION OF OUTCOME
-------------------------	-----------------------

 <p>2.1 Creativity and aesthetic sense</p>	<p>Creativity: the vehicle of human self-expression, involving the capacity to find new and unexpected connections, new relationships and therefore new meanings; aesthetic sense, the appreciation and awareness of experiences that are perceived through the senses.</p>
<p>2.1.1 Creativity expressed</p>	<p>Exploration and expression of own creativity, evidenced through dynamic movement or vocal (including verbal) expression.</p>
<p>2.1.2 Experience of aesthetic enrichment</p>	<p>Having an experience that comes through the senses that makes or recognises something as more significant, meaningful or valuable. This encompasses experiences outside the mundane and every day, most often associated with pleasurable emotions of joy, awe and wonder, arising from perceptions of beauty. It also includes the breadth of emotional and cognitive experiences evoked through experiencing and processing creative experiences. The term enrichment is used rather than beauty or pleasure because these experiences are not necessarily beautiful or pleasurable, but are seminal for the fullest human existence, such as being challenging, provoking or unsettling. They can be as trivial as a sense of escape from daily life or captivation in the moment, to deeper feelings of being moved or intensely engaged.</p>
<p>2.1.3 Aesthetic decision-making</p>	<p>Expression of personal choices based on response to aesthetic stimuli, a hedonic response to a sensory experience engaging any or all of the sensory domains. This might include response to, or interpretation of, a creative stimulus, exploration or expression of ideas and creative intention.</p>

 <p>2.2 Cultural appreciation and belonging</p>	<p>Appreciation of diverse forms of cultural expression, sense of collective identity and the feeling of belonging to a culture</p>
<p>2.2.1 Appreciation of diversity and difference of cultural expression</p>	<p>Development of appreciation, which includes enjoyment, celebration or treasuring, of the value and quality of the different ways that people express themselves including through creative practices, depending on</p>

		their cultural backgrounds, life experience and interests. In DMT, this might include recognising value and showing pleasure in seeing or participating in different forms of social or traditional dances.
2.2.2	Sense of belonging to a shared cultural heritage experienced	Expansion or intensification of one's relationship to members of a culture and their values, practices, and social, symbolic, and material ties. Culture might be considered those practices shared with an ethnic, language or spiritual group, but also an artistic or aesthetic community. Where cultural heritage is defined as an expression of ways of living, developed by a community and passed on from generation to generation, the sense of belonging is related to shared experiences and feelings of inclusion with that group. In DMT this might come about through the use of traditional cultural practices in the therapeutic experience that has the result of a member of that culture feeling a stronger connection to their own culture in the process.

ABOUT THE EMOTIONAL DOMAIN

Towards healthy, regulated emotions

The Emotional Domain in this Framework, the endpoint is for of 'healthy regulated emotions', with 'healthy' being considered and 'regulated' being an individual's controlled emotions: how and what they are and are expressed. The outcomes of healthy and regulated are equally applicable to all people, from those who are experiencing normal states of emotional health and wellbeing and those who are facing particular challenges. The premise of this *Framework* is that humans living in ever-changing internal and external environments need access to different emotional responses as part of a healthy life. Access to a range of states and the ability to move between them as appropriate for their circumstances and experiences are critical. It must also be acknowledged that cultural norms and beliefs of a society affect and shape the emotional expressions of its members, so what is considered 'appropriate' emotional expression will depend significantly on the cultural context. It is the therapist' and participant's task to determine what is healthy and sufficiently regulated given the context of the participant.

This domain comprises two sub-domains of: Emotional expression and Emotional regulation. Emotional expression involves behaviours that communicate an emotional state or attitude. Individuals have some conscious control of their emotional expression, which can be verbal or non-verbal, and can occur with or without self-awareness. Emotional expression includes facial movements like smiling or scowling, and simple behaviours like crying and laughing. Emotional regulation is the process by which individuals influence which emotions they have, when they have them, and how they experience and express their feelings. Emotional regulation can be automatic or controlled, conscious or unconscious, and may have effects at one or more points in the emotion producing process (Gross et al, 1998). It encompasses both positive and negative feelings, along with how we can strengthen them, use them, and control them.

The emotional domain is significant in creative arts therapies, with emotional expression and regulation being identified as one of the active factors of these modalities (Koch, 2017). The relationship to DMT is evidenced in Van der Kolk's acknowledgement that self-regulation, a key component for a client to begin to manage self, requires a friendly relationship with one's body (2014, 97), and Chaiklin's position that DMT contributes to gradual building of a coherent body image, which improves self-image (2017). The non-verbal domains of relatedness are brought into prominence in DMT by a prioritization of feeling over words (Lauffenburger, 2020). DMT enables articulation and expression of inner feelings in specific movement qualities and narrative expression through movement sequences (Samaritter, 2018).

Empirical evidence for the constructs (how DMT works) and outcomes (if it works, for whom) in this domain include findings that emotional expression is stimulated by active creation such as in improvisation in which patients have more control over and distance to their inner experience (Koch, 2019); and that dance techniques including circle dances bring fun, promote exuberance and activity and outcomes of joy, enjoyment, hedonism and play (Koch, 2019). A specific movement of the vertical trajectory of jumping was found to cause a decline of depression (Koch et al, 2007).

DMT has been found to reduce stress (Brauninger, 2012 a, b) and psychological distress (Koch et al, 2014; Peters, 2012; Kiepe et al, 2012; Boehm et al, 2014; Meekums et al, 2015); improve wellbeing (Koch et al, 2014; Peters, 2012) and body image (Koch et al, 2014) including for cancer patients (Mannheim & Weiss, 2006); and improve anxiety levels and depression, for adolescent girls with mild depression (Jeong et al, 2005) and cancer patients (Boehm et al 2014; Archer et al 2015). Self- confidence and coping, enabled by emotional processes through DMT has been shown to strengthen for cancer patients (Mannheim & Weiss, 2006); and psychological functions have shown improvement for patients with fibromyalgia (Horwitz, 2006). DMT is identified as particularly useful for addressing negative symptoms for people experiencing schizophrenia, such as void or lack of perception, apathy, mood and blunted affect, with self-awareness improved by body-mind integration (Rohricht & Priebe, 2006; Lee et al, 2015; Martin et al, 2016; Pohlmann et al, 2017).

OUTCOME DOMAIN 3  3. Emotional Domain TOWARDS HEALTHY, REGULATED EMOTIONS	EMOTIONAL TOWARDS HEALTHY, REGULATED EMOTIONS
---	--

SUB-DOMAIN & OBJECTIVES	DEFINITION OF OUTCOME
-------------------------	-----------------------

3.1 	Emotional expression	Expression of internal emotional or affective states through embodied behaviours or movement and vocal (including verbal) expressions
3.1.1	Identification of own feeling or emotional states	Identification of own feeling or emotional states and make this known through embodied, vocal or verbal responses.
3.1.2	Expression of own feeling or emotional states	Expression of own feeling or emotional states through embodied, vocal or verbal responses.
3.1.3	Experience of fun, pleasure, enjoyment	Experiences of fun, pleasure, enjoyment as evidenced in: level of engagement and enthusiasm; verbal, vocal and embodied communication indicating enjoyment, across the range from non-communicative (silent, withdrawn) to very communicative (laughing, talking, smiling, spontaneous comments); eye contact; body posture.
3.1.4	Access to playfulness	Access to playfulness (an attitude of a person when he or she is engaged mentally and physically in the state of play). Any situation can be approached in a playful manner when the person is in such frame of mind. Involves presence, responsiveness, lightness, attentiveness, improvisation and creativity, a willingness to let go and become part. This can occur when one is alone or engaged with others.
3.1.5	Access to full range and intensity of affects	Access to the complete continuum of human affects, emotion or feelings, in intensity and range, as appropriate to the circumstances. The range of affect includes broad (normal), restricted (constricted), blunted, or flat. The normal expression of affect involves variability in facial expression, pitch of voice, gestures (using hand and body movements). Restricted affect is characterized by a clear reduction in the expressive range and intensity of affects. Blunted affect is marked by a severe reduction in the intensity of affective expression. In flat affect there is a lack of signs of affective expression, the voice may be monotonous and the face, immobile.
3.1.6	Sense of positive body image	Holding a positive sense of self, especially a subjective appreciation of one's own body, that is evident in the body, involving how a person sees themselves, notwithstanding standards and expectations set by society.
3.1.7	Sense of confidence in self	Positive feelings and thoughts of trust or belief in own abilities and capacities

3.2 	Emotional regulation	Response to ongoing demands of experience with a range of emotions, that is socially tolerable and sufficiently flexible, and both permits and delays spontaneous reactions.
3.2.1	Expression of feelings and emotions appropriate to current situation	Display of mood or affect that is considered appropriate, as assessed by other/s present, given task, context and participant's circumstances.

3.2.2	The capacity to cope with challenges and difficulties	Tolerance of ambiguity of emotions, and emotions that are difficult to express in words, such as ambivalence or frustration about one's personal situation and/or challenges arising in the course of the activity.
3.2.3	Release of psychological tension	Capacity to release psychological tension, stress or pressure, that may be evidenced in sense of being fully present or being at ease; quieting of superfluous verbal or non-verbal engagement; relaxed stillness; deep, slow regulated breathing.

ABOUT THE COGNITIVE DOMAIN

Towards an active, enquiring mind

The Cognitive is the domain of learning, thinking and mental processing, comprising the set of mental abilities needed to carry out any task from the simplest to the most complex, such as skills of language, memory and conceptualizing (Koch et al, 2019). In this Framework, the domain's endpoint is of an 'active enquiring mind', with 'active' being defined as dynamic and energised and 'enquiring' meaning interested, engaged with something to learn, to grow, to advance. This is a state that is relevant to all humans, whatever their cognitive capacity and advantages or challenges. What an 'active and enquiring mind' looks like for child with high-functioning autism or an elderly person with advanced dementia will be entirely different, of course, but we can assume that we would wish for both such people, the most active and enquiring state possible.

It comprises three sub-domains of: Attention and Initiative; Memory; and Executive Function. Attention is defined as the cognitive process of selectively concentrating on a discrete aspect of information, while ignoring other perceivable information, which occurs in a state of arousal, while Initiative is the ability to assess and instigate things independently, that is underpinned by a motivation to get things happening. Memory is the faculty of the brain by which information is encoded, stored and retrieved when needed. It is the retention of information over time for the purpose of influencing future action. Memory is understood as an informational processing system with explicit and implicit functioning that is made up of a sensory processor, short-term (or working) memory, and long-term memory. Executive Function involves three core capacities: working memory, inhibition and shifting, which combine to support higher order cognitive processing (eg. problem solving) required for a person to be goal-directed, resist contrary impulses and distractions and pursue more positive (rather than most immediate) outcomes.

Theory from DMT relevant to this domain include Chaiklin's (2017) position that DMT enables access to memory and information not available to the conscious mind. In DMT, participants work dynamically with the inner and outer experiences of change, welcoming with curiosity the fluctuating somatic sensations and movement impulses that underlie feelings (Panksepp, 2005). Through playful explorations, participant and therapists actively co-regulate the process and tolerance of change. Over time co-regulation and self-regulation are felt and embodied and one's ever changing feelings become tolerable and management (Capello, 2016; Homan, 2010). Becoming emotionally nimble, resilient and adaptive is facilitated through consistently working with the ongoing dynamic changes occurring in dance (Lauffenburger, 2020).

Empirical evidence for the contribution of dance and DMT in this domain includes: improved cognitive skills (Koch et al, 2019); improved cognitive capacity and memory function (Coubard, Duretz, Lefebvre, Lapalus & Ferrufino, 2011); and cognitive benefits for adults with intellectual disability (Guerra-Balic et al, 2017).

<p>OUTCOME DOMAIN 4</p> <div style="text-align: center;">  <p>4. Cognitive Domain TOWARDS AN ACTIVE, ENQUIRING MIND MINDTOWARDS AN ACTIVE, ENQUIRING MIND</p> </div>	<p>COGNITIVE TOWARDS AN ACTIVE, ENQUIRING MIND</p>
---	--

SUB-DOMAIN & OBJECTIVES	DEFINITION OF OUTCOME
-------------------------	-----------------------

<p>4.1</p> 	<p>Attention and initiative</p>	<p>Attention: capacity to selectively concentrate on discrete aspects of information, while ignoring other perceivable information; initiative: the ability to begin activities independently.</p>
4.1.1	Attention to activity	Attention to current activities, using either: selective attention (ability to attend to stimuli while ignoring distractions); sustained attention (ability to maintain attention over extended time); divided attention (ability to attend to more than one task simultaneously); alternating attention (ability to shift attention from one task to another without losing focus).
4.1.2	Energy attuned appropriately to activity	Use of energy or response, or engagement in an activity, that seems suitable or appropriate to other/s present, given the task and context.
4.1.3	Preferences and choice-making	Indication offered of what one enjoys or prefers, or to make choices between options.
4.1.4	Independent initiation of an action or activity	Use of own initiative, without prompting, to begin an activity or action.
4.1.5	Leading, taking ownership of an activity	Taking the lead or responsibility for the execution of an activity.

<p>4.2</p> 	<p>Memory</p>	<p>The capacity of the mind and body to store and remember information; recall or recognise previous experience.</p>
4.2.1	Sense of enthusiastic anticipation evident	Pleasure at anticipation of involvement, indicating memory of enjoyment of previous activities, demonstrated through verbal/vocal or embodied communication.
4.2.2	Recall of movement sequences	Recall of movement sequences from previous activities, evidenced through verbal/vocal or embodied communication.
4.2.3	Recall of themes or ideas from previous activities	Recall of themes or ideas from previous activities, evidenced through verbal/vocal or embodied communication.
4.2.4	Meaningful evocation and exploration of life memories	Re-invigoration, re-awakening or examination of memories from one's life that are important or significant, evidenced in embodied or verbal/vocal communication.

<p>4.3</p> 	<p>Executive function</p>	<p>The set of cognitive, metacognitive and emotional processes necessary for adaptive functioning in daily life, a set of mental skills to help us get things done.</p>
4.3.1	Following directions	Attention to and following of instructions or directions, for one or a sequence of tasks
4.3.2	Processing speed	The speed of processing mental tasks, including understanding and reacting to information, either visual (letters and numbers), auditory (language), or movement.

4.3.3	Reflective capacity	Ability to reflect on previous experience and its meaning or implications, and to understand self and others in terms of intentional mental states, such as feelings, desires, wishes, goals and attitudes.
4.3.4	Organisation of thinking, making connections, identifying patterns	Access to higher order thinking that enables observation of connections or patterns between different aspects of one's experience and relevant life situations.
4.3.5	Attribution of mental states to oneself and other (Theory of mind)	Ability to attribute mental states – such as beliefs, intents, desires, emotions, knowledge – to oneself, and others, and understand that others have beliefs, desires, intentions and perspectives that are different from one's own.

ABOUT THE SOCIAL DOMAIN

Towards satisfying reciprocal relationships

The Social domain focusses on the aspects of the therapeutic experience that are about relationships, the connections between people and the way they communicate with each other. It has the endpoint of *satisfying reciprocal* relationships, with the descriptor *satisfying* used to denote the adequacy or quality of relationship/s as they are experienced by each individual, whose needs from relationships are different, and whose needs from *each* relationship is different. Thus, *satisfying* is not intended as an objective quality judgement of a relationship, but a judgement about its fit for the person experiencing the relationship at that time, as they perceive it. The quality of *reciprocal* is a critical adjunct to *satisfying*, because of the necessity that relationships must work for both/all people in them if they are to be truly *satisfying*.

This domain has three sub-domains of Embodied (non-verbal) communication; Social reciprocity and Expressive (including verbal and vocal) communication.

This domain includes social skills that are considered to be "socially acceptable learned behaviors that enable a person to interact with others in ways that elicit positive responses and assist in avoiding negative responses" (Elliott, Racine, & Busse, 1995, p. 1009). Effective social skills allow individuals to elicit positive reactions and evaluations from peers as they perform socially approved behaviors (Ladd & Mize, 1983). Social skills are distinguished from *social competence*, in that *social skills* represent behaviors that must be learned and performed, and *social competence* represents judgment of those behaviors by others (Gresham, 2002). Adequate social competence ensures effective social engagement and reciprocity in the social environment.

Embodied communication

Social reciprocity is the back-and-forth flow of social interaction, during which the behaviour of each person influences the behaviour of the other person. This begins in very young children showing interest in interacting with others and exchanging smiles. This builds to being able to share conventional meanings with words, and later topics, in conversation. Reciprocity requires people to be invested in their relationship. If a relationship is important enough to them, partners will be emotionally invested in it enough to work at building and maintaining it. Commitment is sustained through the improvement of reward-cost balance in relationships. These include skills that people apply in social interaction: empathy, synchronization, communication, pro-social behaviour, self-other awareness, maintaining a relationship (Koch et al, 2019).

Spatial preference varies from person to person and from culture to culture (Kornblum, 2002) and for this reason the ability to recognize boundary crossings and spatial intrusion is not necessarily an innate skill, but one that often requires attention, especially in a multicultural context (Casey, 2018).

Expressive communication

These tasks of embodied (non-verbal) communication; social reciprocity and expressive (including verbal and vocal) communication encompass the task of social cognition, a complex set of skills used to assess the social context of a situation, observe the verbal and nonverbal behaviour of other people, infer their mental states, understand what is expected, and then carry that out.

The social domain is significant as a process in creative arts therapies with communication and social interaction being identified as one of their active factors (Koch, 2017). DMT specifically contributes in this domain by activating non-verbal attunement, communication, enactive empathy, and shared playful experiences that support empathetic sense making between participants (Samaritter, 2018).

Empirical evidence for outcomes of dance and DMT in the social domain include: experiences of solidarity with other people enabled by techniques such as circle dances (Koch, 2019), improvement of interpersonal competence (Koch et al, 2014); and interpersonal skills (Koch, 2019); decreased problematic behaviours and increased social interaction and enjoyment for residents with dementia in care homes (Vancea, 2013); and increased sense of communal belonging fostered through use of attunement and empathy for former child soldiers in Sierra Leone (Harris, 2007).

<p>OUTCOME DOMAIN 5</p> 	<p>SOCIAL TOWARDS SATISFYING, RECIPROCAL RELATIONSHIPS</p>
--	--

SUB-DOMAIN & OBJECTIVES	DEFINITION OF OUTCOME
-------------------------	-----------------------

<p>5.1</p> 	<p>Embodied (non-verbal) communication</p>	<p>Use and management of one's embodied self in relationship, as the most fundamental skill in establishing and maintaining healthy and rewarding relationships with diverse individuals and groups. This form of communication is often automatic and unconscious.</p>
<p>5.1.1</p>	<p>Comfort in proximity to others</p>	<p>Management of oneself with comfort in the physical presence of others. Being able to attend and be present with sufficient comfort.</p>
<p>5.1.2</p>	<p>Appropriate eye gaze or contact</p>	<p>Use of eye gaze or contact in relationship that others in the context perceive as appropriate, given the task, context and relationship between people involved. Includes considerations of frequency and length of glances and blink rate.</p>
<p>5.1.3</p>	<p>Appropriate facial expression</p>	<p>Expression of the face that others in the context perceive as appropriate, given the task, context and relationship between people involved.</p>
<p>5.1.4</p>	<p>Appropriate use and reception of touch</p>	<p>Capacity to <i>distinguish, apply</i> and <i>receive</i> touch, that other/s in the context perceive as appropriate, given the task, context and relationship between people involved.</p>
<p>5.1.5</p>	<p>Appropriate physical contact or connection with others</p>	<p>Use of physical contact or connection in relationship that other/s in the context perceive as appropriate given the task, context and relationships between people involved.</p>
<p>5.1.6</p>	<p>Appropriate use of personal space in relation to others, including body boundaries</p>	<p>Use of personal space appropriately for the task, to manage being as close or as far from others as the situation demands, and that other/s present feel is appropriate given the task, context and relationship between people involved.</p>

<p>5.2</p> 	<p>Social reciprocity</p>	<p>Social reciprocity is the give and take in relationship that enables healthy and mutually rewarding relationships. This requires the ability to have an adequate response to others, involving capacity to assess the social situation, observe verbal and embodied behaviour of others and respond appropriately</p>
<p>5.2.1.</p>	<p>Appropriate response to offer of social connection</p>	<p>Response to contact offered by other/s, that other/s in the context perceive as appropriate, given the task, context and relationship between people involved.</p>
<p>5.2.2.</p>	<p>Appropriate initiation, sustainment, release of social connection</p>	<p>Capacity to <i>begin, continue</i> and <i>let go</i> of connection (physical or other) with other/s, that other/s in the context feel is appropriate given the task, context and relationship between people involved.</p>
<p>5.2.3</p>	<p>Appropriate give and take in relationship, turn-taking</p>	<p>Capacity to experience and create reciprocity; to take turns or wait; hold back or step forward, that other/s in the context perceive as appropriate, given the task, context and relationship between people involved.</p>
<p>5.2.4</p>	<p>Synchrony of movement with others</p>	<p>Capacity to move the body in synchrony with other person/people.</p>

	5.3 Expressive (including verbal and vocal) communication	Abilities used when giving and receiving different kinds of information, such as sharing feelings and ideas, or what is happening around oneself. Expressive communication skills involve listening, speaking, observing and empathizing, being aware of how we relate to others, the messages we send and how these contribute to our relationships. This includes vocal, verbal and embodied communication and inclusion of emotional content in interactions.
5.3.1	Identification of feelings or emotional states of others	Recognition of emotional state or feelings of others that is concordant with their experience, and evidenced through verbal, vocal and/or embodied communication.
5.3.2	Socially acceptable or appropriate response to emotions of others	Response to others' feelings or emotional states, that other/s present feel is appropriate and acceptable given the task, context and relationship between people involved, and indicated through verbal, vocal and/or embodied communication.
5.3.3	Emotional connection with others	Interest in and capacity for social emotional engagement, desire to be 'seen' and 'recognised', sense of trust or comfort in relationships with others, evidenced through verbal/vocal communication or embodied action.
5.3.4	Receptive communication	Ability to understand information, the words, sentences and meaning of what others say or what is read, including response indicating acknowledgement. May extend to active listening when the listener fully concentrates, understands, responds and then remembers what is being said.
5.3.5	Expressive vocal or verbal communication	Thoughts or feelings expressed through voice or sound.
5.3.6	Appropriate vocal or verbal communication	Communication using voice or sound that seems appropriate to other/s present, given the task, context and relationships between those communicating.
5.3.7	Capacity to reflect on experiences and to communicate them	The use of communication strategies to share with others some sense of contemplative thoughts on own experiences, using embodied, vocal or verbal communication.

ABOUT THE INTEGRATION DOMAIN

Towards wholeness, vitality, aliveness.

This domain brings together all aspects of the person, with wholeness, vitality, aliveness being the highest states possible through the integrated self. Vitalisation is 'investing people with the power to live' (Schmais, cited in Goodill 2006). Experiences that can be considered as occurring within this domain potentially result in changes in behaviours, thinking, attitudes and beliefs about oneself and life as a whole.

The two sub-domains are: Sense of integration within oneself and Sense of integration between self and outside world. The DMT program might support participants to come to higher state and achieve a sense of integration and fulfilment first within themselves and then in relation to the outside world.

Ideas from theory drawn on in this domain include Seligman's flourishing (2011), which is understood as the way we find fulfillment in our lives, accomplishing meaningful and worthwhile tasks, and connecting with others at a deeper level; and Csikszentmihalyi's (1990) concept of flow, defined as a state of concentration or complete absorption with the activity at hand and the situation. The flow state is an optimal state of intrinsic motivation where the person is fully immersed in what they are doing, characterized by a feeling of great absorption, engagement, fulfillment, and skill. This state can occur when skills are matched well to given challenge, with demands neither too low nor high (Csikszentmihalyi, 1997).

Non-verbal meaning-making is posited as one of the active factors of creative arts therapy (Koch, 2017). With respect more specifically to dance, this domain is also supported by Stern's (2010) conception that the elements of dance can psycho-therapeutically activate and integrate the affective (emotional), interactional (social) and cognitive dimensions of self. Sheets-Johnstone (2016) argues that meaning is grounded in our sensori-motor experience and it is through embodiment that meaning can be extended (Lakoff & Johnson, 2002). Caldwell conceptualises the idea of bodyfulness (2018).

Dance movement therapists often dance with their participants in order to create meaning, as personal meaning can be more fully explored through the creative dance movement process (Lauffenburger, 2020). Techniques such as improvisation and authentic movement are used to promote authentic expression and to integrate the unconscious (Koch, 2019).

<p>OUTCOME DOMAIN 6</p>  <p>6. Integration Domain TOWARDS WHOLENESS, VITALITY, ALIVENESS</p>	<p>INTEGRATION: WHOLENESS, VITALITY, ALIVENESS TOWARDS A SENSE OF INTEGRATED SELF ACROSS DOMAINS</p>
---	---

SUB-DOMAIN & OBJECTIVES	DEFINITION OF OUTCOME
-------------------------	-----------------------

<p>6.1</p>  <p>Sense of integration within self</p>	<p>A sense of integration within myself, a feeling of being complete and whole, having vitality, vigour, enthusiasm, positive energy and motivation for change.</p>
<p>6.1.1</p> <p>Integration of past, present and future embodied self</p>	<p>Integrated sense of self and identity, involving a feeling of connection between one's past, the present moment and anticipated future across the domains, experienced through the body.</p>
<p>6.1.2</p> <p>Adaptation to adversity, coping, resilience</p>	<p>Sense of being able to overcome my difficulties, accept my strengths and weaknesses, get things in perspective, feel able to move on or move forward, and function effectively in my environment.</p>
<p>6.1.3</p> <p>Integration of whole self: sensations, feelings, thoughts, imagination</p>	<p>Ability to integrate the whole self, bringing together body sensations (physical), feelings (emotional), thoughts (cognitive) and imagination (cultural-creative and aesthetic) aspects, through movement.</p>
<p>6.1.4</p> <p>Embodied sense of a positive future</p>	<p>Experience of a sense of positivity about one's own future and/or the future of others in one's life or world, evidenced through an enlivened embodiment.</p>
<p>6.1.5</p> <p>Experience of flow state</p>	<p>Experience of being in a state of flow, a feeling of being fully present and immersed in a sense of energized focus, through enjoyment in the embodied process of an activity.</p>

<p>6.2</p>  <p>Sense of integration between self and outside world.</p>	<p>A sense of integration between myself and the world around me, including other people, but also other living and non-living things and beings. A feeling of things coming together, being unified and connected, a sense of wholeness and completeness.</p>
<p>6.2.1</p> <p>Resonance: sense of felt unity with music, partner or other stimulus</p>	<p>A feeling of deep connectedness to an element of one's experience, either another person or persons or music, prop or idea, evoked through movement or other stimulus.</p>
<p>6.2.2</p> <p>Embodied pleasure and sensuality</p>	<p>Experience of embodied pleasure; enjoyment of physical closeness, intimacy or connection with an/other; enlivened sense of identity in sensual or sexual sense, feeling of positive activation of gender identity; embodied sense of affirmation of self in the moment and into the future.</p>
<p>6.2.3</p> <p>Experience of sense of meaning, spiritual or numinous connection or transcendence</p>	<p>Deep experiences of a sense of meaning, of life itself or particular aspects of it; or sense of connection to aspects of life beyond the immediate here and now, and self. This can include spiritual connection for those with beliefs about religion or some kind of higher power or other world, but also numinous, uplifting transcendent experiences for those without such beliefs.</p>

6.2.4	Sense of belonging and becoming, connection and contribution	A feeling of becoming one's full self, belonging to, contributing or making a difference to a group, family, community, cause or problem outside oneself; sense of the greater social whole; social conscience.
-------	---	---

COMPREHENSIVE MODEL DEPICTING RELATIONSHIPS BETWEEN THE DOMAINS

Evidence of the construct validity, using a confirmatory factor analysis (CFA), is a hypothesis-testing approach to the analysis of a structural theory, bearing on some phenomenon (Byrne, 2016). In this case we aim to identify which objectives belong together, which are grouped as factors (sub-domains and domains) in order to confirm the proposed comprehensive model. Structural equation modelling (SEM) is a statistical procedure that conveys two aspects of the procedure: (a) that the causal processes under study are represented by a series of structural (regression) equations, and (b) that these structural relations can be modelled pictorially to enable a clearer conceptualization of the theory under study (Byrne, 2016). Using this procedure, the hypothesized comprehensive model of the Outcomes framework can be tested statistically in a simultaneous analysis of the entire set of variables (items) to determine the extent to which it is consistent with the data gathered (assessments). If goodness-of-fit is adequate, the model argues for the plausibility of the postulated relations among variables. These findings will provide evidence whether the framework underlying MARA is a psychometrically tested and validated instrument for measuring outcomes in DMT and other body oriented therapies.

The Outcomes framework, covers six domains: Physical (D1); Cultural (D2); Emotional (D3); Cognitive (D4); Social (D5); Integration (D6), see Table 4.

The number of variables by domain is respectively, 30 in D1, 5 in D2, 10 in D3, 14 in D4, 17 in D5 and 9 in D6. Considering all the 6 Domains, 17 sub-scales (defined as sub-domains) are proposed, comprising, respectively, in D1, 5 (SD1_1 Body parts: awareness, activation, connection; SD1_2 Space: Body in space; SD1_3 Shape: Body shaping ; SD1_4 Effort: Movement qualities; SD1_5 Fitness and release); in D2 2 sub-domains (SD2_1 Creativity and aesthetic sense; SD2_2 Cultural appreciation and belonging); in D3, 2 sub-domains (SD3_1 Emotional expression; SD3_2, Emotional regulation); in D4 3 sub domains (SD4_1 Attention and initiative; SD4_2 Memory, SD4_3 Executive function); in D5 2 sub domains (SD5_1 Embodied (non-verbal) communication; SD5_2 Social reciprocity; SD5_3 Expressive (including verbal and vocal) communication) and in D6, 2 sub-domains (SD6_1 Sense of integration within oneself; SD6_2 Sense of integration between self and outside world), see Table 5.

In total, the Outcomes framework consists of 85 single items, defined in this model as objectives, see Table 6.

D1	PHYSICAL: TOWARDS A STABLE, MOBILE, FUNCTIONAL AND EXPRESSIVE BODY
D2	CULTURAL: TOWARDS A CREATIVE, AESTHETIC, EXPRESSIVE SELF
D3	EMOTIONAL: TOWARDS HEALTHY, REGULATED EMOTIONS
D4	COGNITIVE: TOWARDS AN ACTIVE, ENQUIRING MIND
D5	SOCIAL: TOWARDS SATISFYING RECIPROCAL RELATIONSHIPS
D6	INTEGRATION: TOWARDS WHOLENESS, VITALITY, ALIVENESS

Table 4 Proposed factor structure comprising 6 Domains (Latent variables in CFA)

SD1_1	Body parts: Awareness, activation, connection
SD1_2	Space: Body in space
SD1_3	Shape: Body shaping
SD1_4	Effort: Movement qualities
SD1_5	Fitness and release
SD2_1	Creativity and aesthetic sense
SD2_2	Cultural appreciation and belonging
SD3_1	Emotional expression
SD3_2	Emotional regulation
SD4_1	Attention and initiative
SD4_2	Memory
SD4_3	Executive function
SD5_1	Embodied (non-verbal) communication
SD5_2	Social reciprocity
SD5_3	Expressive (including verbal and vocal) communication
SD6_1	Sense of integration within oneself
SD6_2	Sense of integration between self and outside world

Table 5 Sub-domains : proposed second order six factor structure comprising 17 sub-domains (Latent variables in CFA)

I1_1_1	Use of breath to support movement
I1_1_2	Activation of body parts: upper, lower body
I1_1_3	Activation of body hemispheres: left, right
I1_1_4	Body parts connection: centre to extremities, head to tail connections
I1_1_5	Body parts connection: upper and lower body
I1_1_6	Body halves connection: right and left sides
I1_1_7	Body parts connection: diagonal movement
I1_1_8	Sequencing of body parts in movement
I1_1_9	Self-synchrony: body parts moving in rhythm with oneself
I1_1_10	Control of movement succession
I1_2_1	Kinaesphere: access to near-, mid- and far- reach space
I1_2_2	Movement planes: access to vertical, horizontal, sagittal planes
I1_2_3	Spatial intention: mover identifies and uses directions or points in space
I1_2_4	Levels in space: access to low, medium, high levels
I1_2_5	Managing body boundaries in space
I1_3_1	Shape Flow: access to Shape Flow, representing a relationship of the body to itself
I1_3_2	Directional: access to Directional Shaping of the body
I1_3_3	Carving: access to Space Carving, the body's active and three-dimensional interaction with the volume of the environment
I1_3_4	Shape qualities: access to Shape qualities, opening and closing
I1_4_1	Weight: access to Active (light - strong) and Passive (limp - heavy) Weight Efforts
I1_4_2	Space: access to Direct - Indirect Space Efforts
I1_4_3	Time: access to Sudden-Sustained Time Efforts
I1_4_4	Flow: Access to Bound - Free Flow Efforts
I1_4_5	Effort combinations: access to combinations of Effort elements
I1_4_6	Effort phrasing: access to Effort phrasing
I1_5_1	Stamina
I1_5_2	Strength
I1_5_3	Flexibility
I1_5_4	Balance
I1_5_5	Release of physical tension
I2_1_1	Creativity expressed
I2_1_2	Experience of aesthetic enrichment
I2_1_3	Aesthetic decision-making
I2_2_1	Appreciation of diversity and difference of cultural expression
I2_2_2	Sense of belonging to a shared cultural heritage experienced
I3_1_1	Identification of own feeling or emotional states
I3_1_2	Expression of own feeling or emotional states
I3_1_3	Experience of fun, pleasure, enjoyment
I3_1_4	Access to playfulness
I3_1_5	Access to full range and intensity of affects
I3_1_6	Sense of positive body image
I3_1_7	Sense of confidence in self
I3_2_1	Expression of feelings and emotions appropriate to current situation
I3_2_2	The capacity to cope with challenges and difficulties
I3_2_3	Release of psychological tension
I4_1_1	Attention to activity
I4_1_2	Energy attuned appropriately to activity
I4_1_3	Indication of preferences and choice-making
I4_1_4	Independent initiation of an action or activity
I4_1_5	Leading, taking ownership of an activity
I4_2_1	Sense of enthusiastic anticipation evident
I4_2_2	Recall of movement sequences
I4_2_3	Recall of themes or ideas from previous activities
I4_2_4	Meaningful evocation and exploration of life memories
I4_3_1	Following directions
I4_3_2	Processing speed
I4_3_3	Reflective capacity
I4_3_4	Organisation of thinking, making connections, identifying patterns
I4_3_5	Attribution of mental states to oneself and other (Theory of mind)
I5_1_1	Comfort in proximity to others
I5_1_2	Appropriate eye gaze or contact
I5_1_3	Appropriate facial expression
I5_1_4	Appropriate use and reception of touch
I5_1_5	Appropriate physical contact or connection with others
I5_1_6	Appropriate use of personal space in relation to others, including body boundaries
I5_2_1	Appropriate response to offer of social connection
I5_2_2	Appropriate initiation, sustainment, release of social connection
I5_2_3	Appropriate give and take in relationship, turn-taking
I5_2_4	Synchrony of movement with others
I5_3_1	Identification of feelings or emotional states of others
I5_3_2	Socially acceptable or appropriate response to emotions of others
I5_3_3	Emotional connection with others
I5_3_4	Receptive communication
I5_3_5	Expressive vocal or verbal communication
I5_3_6	Appropriate vocal or verbal communication
I5_3_7	Capacity to reflect on experiences and to communicate them
I6_1_1	Integration of past, present and future embodied self
I6_1_2	Adaptation to adversity, coping, resilience.
I6_1_3	Integration of whole self: sensations, feelings, thoughts, imagination
I6_1_4	Embodied sense of a positive future
I6_1_5	Experience of flow state
I6_2_1	Resonance: sense of felt unity with music, partner or other stimulus.
I6_2_2	Embodied pleasure and sensuality
I6_2_3	Experience of sense of meaning, spiritual or numinous connection or transcendence
I6_2_4	Sense of belonging and becoming, connection and contribution.

Table 6 Proposed Items/Objectives (observed variables in CFA)

We hypothesize two models:

(a) **A first-order CFA model**, testing the hypothesis that MARA Outcomes framework is a multidimensional construct composed of six intercorrelated factors (D1, D2, D3, D4, D5, D6), see Figure 9.

(b) **A second-order model**, with one higher order factor (MARA) as a result of six lower order factors (D1, D2, D3, D4, D5, D6). This model examines the theorized construct where 17 underlying sub-constructs are posited. So, the six domains are considered as sub-constructs, and each sub-constructs is measured using certain number of items. The second-order model represents the hypothesis that these factors are seemingly distinct, but related constructs that can be accounted for by one common underlying higher order construct, see Figure 10.

In comparison to first-order model with correlated factors, second-order factor models can provide a more parsimonious and interpretable model when researchers hypothesize that higher order factors underlie their data.

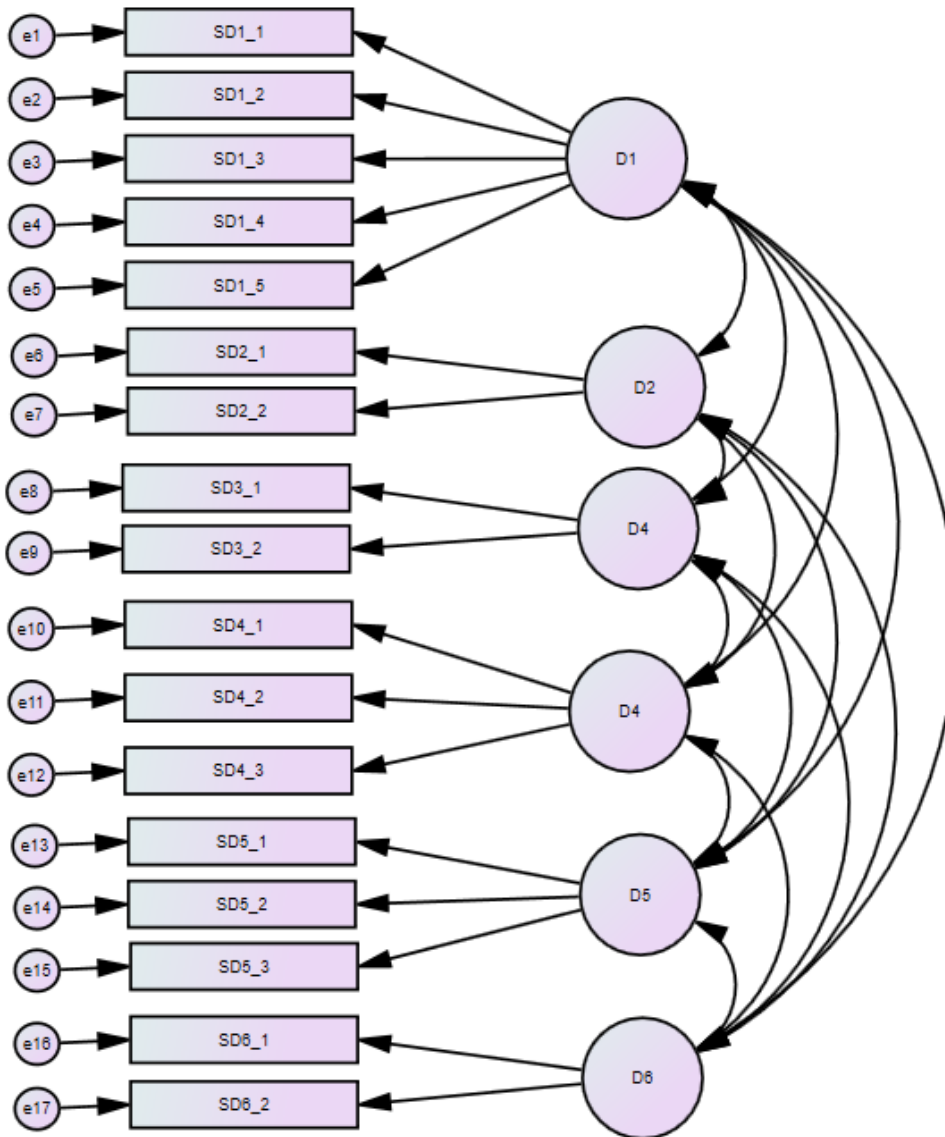

Figure 9 First order six factor model

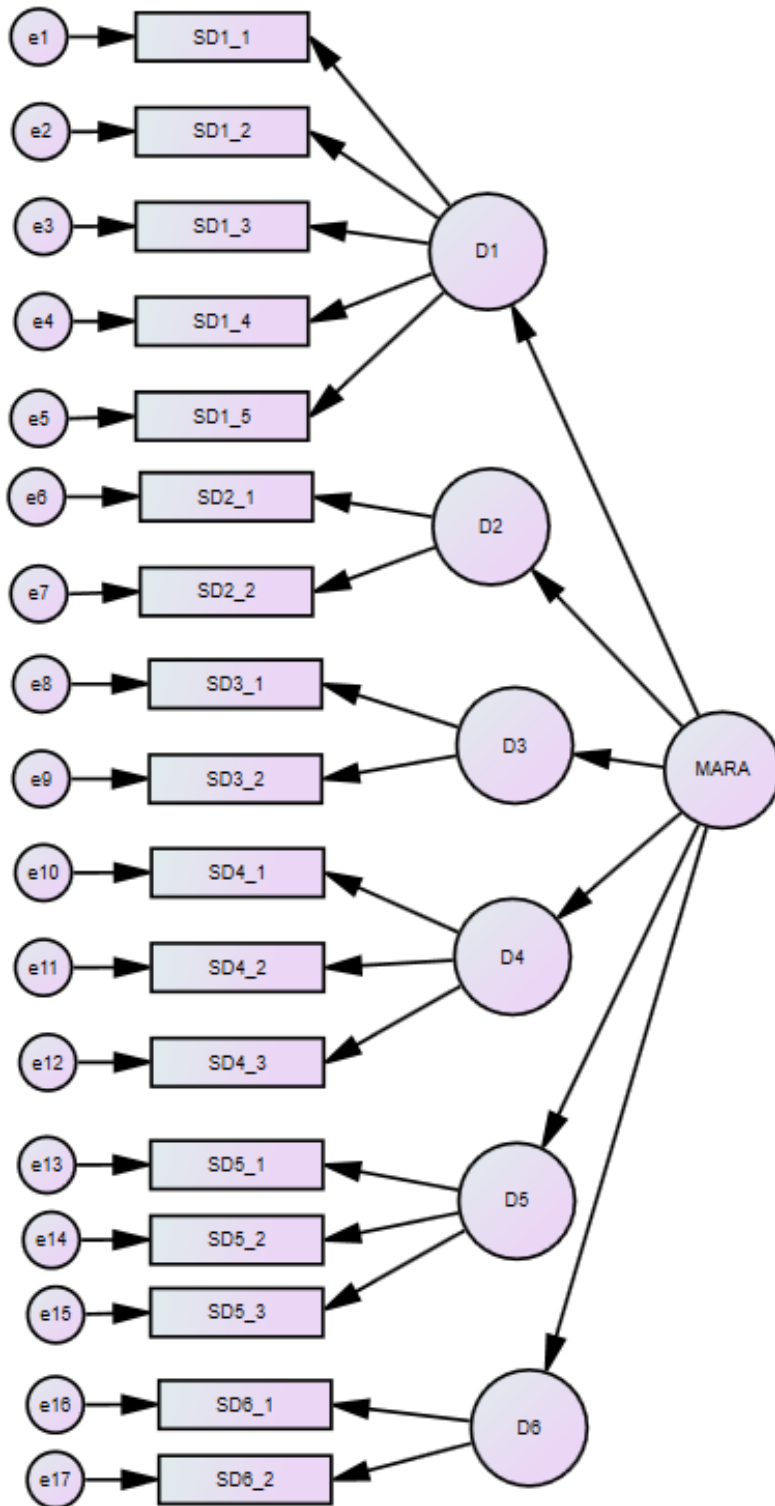

Figure 10 Second order single factor model

Glossary

Ability: actual skill that has been acquired

Assessment: The process of understanding, analysing or measuring the participant's progress within a framework or goals and objectives set for the therapeutic program, ie. How quickly or effectively the participant is reaching the objectives set for the CAT program.

Capacity: the potential to develop a skill elicited by environmental stimulation

Evaluation: an examination of the actual value or success of the program itself i.e. does dance movement therapy, when it is applied in this way, provide a participant with an effective means of reaching his/her goals?

Formative assessment: The goal of formative assessment is to monitor participant *progress* and provide ongoing feedback that can be used by therapists to improve their practice and by participants to improve their progress. More specifically, formative assessments:

- help participants identify their strengths and weaknesses and target areas that need work
- help therapists recognize where participants are struggling and address problems immediately

Intake assessment: Intake assessment is a process undertaken at the beginning of the therapeutic relationship. It is concerned primarily with gathering information so that the practitioner can put together a working base to deal with a participant's issues.

Goals: the result or achievement that effort is directed towards; an intention for the desired future. This is a long term proposition that is always aspirational and may never be fully achieved. While we may make progress towards this goal, we are likely never to get to a point where we believe we have reached the maximum

Objectives: the intended outcome: a specific result that a person or system aims to achieve within a timeframe and available resources. Thus, because it is specific and timely, an objective can be reached.

Outcomes: the consequences directly attributable, at least in part, to the program or project and are usually measured at, or shortly after, completion. Ideally these match objectives (thus they are intended outcomes), ie. we achieve what we set out to achieve, but we cannot be sure that we will do so when we start.

Summative assessment: the process of evaluating participant progress at the end of a period of time by comparing it against some standard or benchmark.

Acknowledgements

Framework development: Dance movement therapy practitioners and researchers across the world who have responded to requests to participate in research. These include JungHsu Wan, New Zealand; Connor Kelly, Guam; Cecelia Fontanesi, Italy, USA; Alida Esmail, Canada; Patti Russell-Curry, Ming Jung Shim, USA, Korea; Josephine Geipel, Sabine Koch, Germany, Simea Schoenenberger, Switzerland; Jenny Scott, Tessa Hens, Australia.

Logos design: Whatdesign & MOSAICO - Plataforma de projetos inclusivos artísticos e educativos, Portugal (*The idea behind the logo for MARA as a mosaic. The Mosaic is the whole... both the whole that is life, and the whole that is the junction of the different dimensions that make up the human being, in diversity, linking dance to the “dance of life”. The image of the domains and sub-domains in mosaic pieces that dance among themselves, merging and make this whole possible. It is this interrelatedness that builds who we are, and the idea that each piece (outcome) helps in the construction of the individual. The mosaic also mean that each individual is a unique work of art, built upon the fusion of small pieces, where each piece is unique and unrepeatable.*)

Photos on the cover page: Igor Pereira

Funding: Support for the development and trialling of the *Outcomes Framework* has been provided by: the University of Melbourne, including a Mackenzie Post-Doctoral Fellowship for project leader Kim Dunphy and an MSEI Community Fellowship for Tessa Hens of Bayley House, Brighton; the Australia-Germany Joint Research Co-operation Scheme, (DAAD); PACFA (Psychotherapy and Counselling Federation of Australia) and an anonymous charitable foundation; and the Hanny Exiner Memorial Fund (of the Dance Movement Therapy Association of Australasia).

In-kind support: Faculdade de Motricidade Humana, Universidade de Lisboa, Portugal for the contribution of Professor Paula Lebre and graduate and post-graduate students Mariana Biscoito, Inês Beles Carolina Silva, Tomás Pereira, Carla Godinho, Alexandra Paula, Ana Caridade, Ana Coimbra; Almada City Council, Dança e Gira Program, Portugal as a trial site with the support of Emilia Prudêncio and Soraia Juma; RIArt, Alanus/Bonn Hochschule, Germany for the contribution of Professor Sabine C. Koch and SRH Hochschule, Heidelberg, for the support of post-graduate students Simea Schoenenberger (M.A.) and Josephine Geipel (M.A.); Bayley House, Melbourne, Australia for the time of Tessa Hens, staff, participants and as a trial site; Professor Sharon W. Goodill, Drexel University, USA, for the contribution to the development of MARA; Columbia College, Chicago, for the time of staff Professor Susan Imus and Laura Allen and post-graduate students Patrick Justin and Hannah Bailey as triallers; Sunshine Special Developmental School, Melbourne, Australia for the work of Sue Mullane, staff, students and families as a trial site; and hundreds of dance movement and other creative arts therapists in Australasia and internationally.

References

- Aguiar, L. & de Rocha, P., & Morris, M. (2016). Therapeutic Dancing for Parkinson's Disease, *International Journal of Gerontology*, 10(20), 64-70. <https://doi.org/10.1016/j.ijge.2016.02.002>
- Ambady, N., Bernieri, F. J., & Richeson, J. A. (2000). Toward a histology of social behavior: Judgmental accuracy from thin slices of the behavioral stream. In M. P. Zanna (Ed.), *Advances in experimental social psychology*, Vol. 32 (p. 201–271). Academic Press. [https://doi.org/10.1016/S0065-2601\(00\)80006-4](https://doi.org/10.1016/S0065-2601(00)80006-4)
- American Dance Therapy Association (ADTA) (2017). *ADTA 2016 Member Survey and Practice Analysis*. Maryland: ADTA. <https://adta.org/wp-content/uploads/2017/09/American-Dance-Therapy-Association-Practice-Analysis-Report-2017.pdf>.
- American Dance Therapy Association (ADTA) (2020). What is dance/movement therapy. <https://www.adta.org/>
- Archer, S., Buxton, S., & Sheffield D. (2015). The effect of creative psychological interventions on psychological outcomes for adult cancer patients: a systematic review of randomised controlled trials. *Psychooncology*. 24(1) 1-10. doi:10.1002/pon.3607
- Bainbridge Cohen, B. (2018). *The Basic Neurocellular Patterns*. Body Mind Centering.
- Bartenieff, I. & Lewis, D. (1980). *Body Movement: Coping with the Environment*. Gordon & Breach.
- Boehm, K., Cramer, H., Staroszyński, T., & Ostermann, T. (2014). Arts therapies for anxiety, depression, and quality of life in breast cancer patients: a systematic review and meta-analysis. *Evid Based Complement Alternat Med*. 2014:103297. doi:10.1155/2014/103297
- Brauninger, I. (2012a). The efficacy of dance movement therapy group on improvement of quality of life: A randomized controlled trial, *The Arts in Psychotherapy*, 39, 4, 296-303. <https://doi.org/10.1016/j.aip.2012.03.008>
- Brauninger, I. (2012b). Dance movement therapy group intervention in stress treatment: A randomized controlled trial (RCT), *The Arts in Psychotherapy*, 39, 5, 443-450. <https://doi.org/10.1016/j.aip.2012.07.002>.
- Burzynska, A. Finc, K., Taylor, B., Knect, A., & Kramer, A. (2017). The dancing brain: structural and functional signatures of expert dance training, *Front. Hum. Neurosci.*, <https://doi.org/10.3389/fnhum.2017.00566>
- Byrne, B. (2016). *Structural Equation Modelling With AMOS: Basic Concepts, Applications, and Programming* (2nd ed.). Routledge.
- Caldwell, C. (2018). *Bodyfulness*. Shambala.
- Capello, P. P. (2016). *BASICS: An intra/interactional model of DMT with the adult psychiatric patients*. In S. Chaiklin & H. Wengrower (Eds.), *The art and science of dance/movement therapy: Life is dance* (p. 77–101). Routledge/Taylor & Francis Group.
- Casey, S.E. (2018). Moving to Prevent Child Sexual Abuse: Dance/Movement Therapy as Primary Prevention. *Am J Dance Therapy*, 40, 240–253. doi.org/10.1007/s10465-018-9286-4
- Chaiklin, S. (2017). Connecting the practice of dance/movement therapy. What differentiates us? *American Journal of Dance Therapy*, 39, 142-147.
- Cohen, B. (1993). *Sensing, feeling and action: The experiential anatomy of Body-Mind Centering*. Contact Editions
- COMET Initiative (2018). The Comet Initiative. <http://www.comet-initiative.org/>.
- Conceição, L. S., Neto, M.G., do Amaral, M.A., Martins-Filho, P.R., & Oliveira Carvalho, V. (2016). Effect of dance therapy on blood pressure and exercise capacity of individuals with hypertension: A systematic review and meta-analysis. *Int J Cardiol*. 220, 553-557. doi:10.1016/j.ijcard.2016.06.182.
- CORC (Child Outcomes Research Consortium) (2020). Who we are. <https://www.corc.uk.net/about-corc/who-we-are/>

Coubard O., Duret S., Lefebvre L., Lapalus P., & Ferrufino L. (2011). Practice of contemporary dance improves cognitive flexibility in aging, *Front. Aging Neurosci.*doi.org/10.3389/fnagi.2011.00013

Cruz, R. (2013). Evaluation and assessment in dance/movement therapy. In R. Cruz and B. Feder (Eds). *The art and science of evaluation in the arts therapies*, 2nd Edn. CC Thomas, pp. 307–33.

Csikszentmihalyi, M. (1990). *Flow: The Psychology of Optimal Experience*. Harper and Row.

Csikszentmihalyi, M. (1997). *The Masterminds series. Finding flow: The psychology of engagement with everyday life*. Basic Books.

Dance Movement Therapy Association of Australasia (DTAA) (2020). What is dance movement therapy. DTAA. <https://dtaa.org.au/therapy/>

de Dreu, M.J., van der Wilk, A.S., Poppe, E., Kwakkel, G., & van Wegen, E.E. (2012). Rehabilitation, exercise therapy and music in patients with Parkinson's disease: a meta-analysis of the effects of music-based movement therapy on walking ability, balance and quality of life. *Parkinsonism Relat Disord.* 18 Suppl 1:S114-S119. doi:10.1016/S1353-8020(11)70036-0

Dell, C. (1977). *A Primer for Movement Description Using Effort – Shape and Supplementary Concepts*, Dance Notation, pp. 43-58.

Department of Human Services (2008). Opportunities in practice: Outcome measurement in mental health, Melbourne: Victorian Government. Retrieved from <https://www2.health.vic.gov.au/mental-health/practice-and-service-quality/service-quality/measuring-outcomes-in-mental-health/outcome-measures-used-in-victoria>

de Natale, E.R., Paulus, K.S., Aiello, E, et al. (2017). Dance therapy improves motor and cognitive functions in patients with Parkinson's disease. *NeuroRehabilitation.* 40(1)141-144. doi:10.3233/NRE-161399

Dunphy, K., Smithies, J., Schauble, H., Stevenson, A., & Uppal, R. (2020). Positing a schema of measurable outcomes of cultural engagement. *Evaluation*.

Dunphy, K. & Hens, T. (2018). Outcome-focussed dance movement therapy assessment enhanced by iPad app MARA. *Frontiers in Psychology.* 9:2067. doi: 10.3389/fpsyg.2018.02067. <https://www.frontiersin.org/articles/10.3389/fpsyg.2018.02067/full>

Dunphy, K., Mullane, S., & Allen, L. (2016). Developing an iPad app for assessment in dance movement therapy, *The Arts in Psychotherapy*, 5 (54-62). doi.org/10.1016/j.aip.2016.09.001.

Dunphy, K. & Scott, J. (2003). *Freedom to Move: Movement and dance for people with intellectual disabilities*, Sydney: Elsevier.

Dunphy, K., Smithies, J., Schauble, H., Stevenson, A., & Uppal, R. (2020). Positing a schema of measurable outcomes of cultural engagement. *Evaluation Journal*.

European Association of Dance Movement Therapy (EADMT) (2020). What is dance movement therapy? <https://www.eadmt.com/?action=article&id=22>

Eddy, M. (2016). *Mindful Movement*. Intellect

Elliott, S. N., Racine, C. N., & Busse, R. T. (1995). Best practices in preschool social skills training. In A. Thomas & J. Grimes (Eds.), *Best practices in school psychology-III*. (pp. 1009-1020). National Association of School Psychologists.

Filar-Mierzwa, K., Długosz, M., Marchewka, A., Dąbrowski, Z., & Poznańska, A. (2017) The effect of dance therapy on the balance of women over 60 years of age: The influence of dance therapy for the elderly, *Journal of Women & Aging*, 29(4) 348-355, doi: 10.1080/08952841.2016.1194689.

Fisher, P. (2017). The recovery journey: The place and value of dance movement psychotherapy with clients with alcohol or substance misuse. In H. Payne, (ed.) *Essentials of Dance Movement Psychotherapy: International perspectives on theory, research, and practice*. Routledge.

Frank, R., & LaBarre, F. (2011). *The first year and the rest of your life: Movement, development and psychotherapeutic change*. Routledge.

Gomes, N. M., Menezes, M.A., & Oliveira Carvalho, V. (2014). Dance therapy in patients with chronic heart failure: a systematic review and a meta-analysis. *Clin Rehabil.* 28(12) 1172-1179. doi:10.1177/0269215514534089

Gross, J.J. (1998). The emerging field of emotion regulation: An integrative review. *Review of General Psychology.* 2(3) 271-299. doi:10.1037/1089-2680.2.3.271

Guerra Balic, M., Barnet-Lopez, S., Signo, S., Testor, S.P., Bruna, O., Solano-Mora, L., & Oveido, G. (2017). Cognitive benefits of a dance movement therapy program in adults with intellectual disabilities, *Medicine & Science in Sports & Exercise*,49,75. doi:10.1249/01.mss.0000517033.34425.61

Hackney, M., & Bennett, C. (2014). Dance therapy for individuals with Parkinson's Disease: Improving quality of life. *Journal of Parkinsonism and Restless Legs Syndrome*, 4,17-25. doi:10.2147/JPRLS.S40042

Hackney, P. (2002). *Making Connections: Total body integration through Bartenieff Fundamentals*. Routledge.

Hanna, J. L. (2008). A nonverbal language for imagining and learning: Dance education in K-1 Curriculum. *Educational Researcher*, 37(8), 491-506.

Harris, D. (2007). Pathways to embodied empathy and reconciliation after atrocity: Former boy soldiers in a dance/movement therapy group in Sierra Leone, *Intervention*, 5(3) 203-231.

Head Start Early Childhood Learning and Knowledge Centre (n.d.) *Head Start Early Learning Outcomes Framework*. U.S. Department of Health and Human Services. <https://eclkc.ohs.acf.hhs.gov/school-readiness/article/head-start-early-learning-outcomes-framework>

Hekkert, P. (2014) What I talk about when I talk about aesthetics. In *Proceedings of the Twenty third Biennial Congress of the International Association of Empirical Aesthetics*. (Ed. A Kozbelt), New York, USA, 22-24 August 2014, pp. 244-246.

Hens, T. & Dunphy, K. (2020). Planning a dance movement therapy program for clients with intellectual disability: considering NDIS, host agency and DMT priorities. *Moving On*, 17(1) 2-17. <https://dtaa.org.au/journal/>

Hens, T., & Dunphy, K. (2020). Developing participant capacity for self-assessment in dance movement therapy. *Journal of Disability and Society*.

Homan, K. B. (2010). Embodied concepts of neurobiology in dance/movement therapy practice. *American Journal of Dance Therapy*, 32(2), 80–99. doi.org/10.1007/s10465-010-9099-6.

Horwitz, E. (2006) Evaluating DMT in fibromyalgia patients - Consequences of verbal, visual and hormonal Analysis. In S. Koch and I. Brauninger (Eds.) *Advances in dance/movement therapy: Theoretical Perspectives and Empirical Findings*. Logos Verlag.

Jeong, Y.J., Hong, S.C., Lee, M.S., Park, M.C., Kim, Y.K., & Suh, C.M. (2005). Dance movement therapy improves emotional responses and modulates neurohormones in adolescents with mild depression. *Int J Neurosci*, 115(12) 1711-1720. doi:10.1080/00207450590958574

Jones, P. (2020). *The arts therapies: A revolution in healthcare*. (2nd ed). Routledge.

Kestenberg Amighi, J., Loman, S., Lewis, P., & Sossin, M. et al (1999). *The meaning of movement: Developmental and clinical perspectives of the Kestenberg Movement Profile*. Brunner-Routledge.

Kiepe, M.S. Stockigt, B., Keil, T. (2012). Effects of dance therapy and ballroom dances on physical and mental illnesses: A systematic review, *The Arts in Psychotherapy*, 39(5), 404-411. <https://doi.org/10.1016/j.aip.2012.06.001>

Koch, S., Morlinghaus, K., Fuchs, T. (2007). The joy dance: Specific effects of a single dance intervention on psychiatric patients with depression, *The Arts in Psychotherapy*, 34(4), 340-349. doi.org/10.1016/j.aip.2007.07.001.

Koch, S., & Fischmann, D. (2011). Embodied enactive dance/movement Therapy. *American Journal of Dance Therapy*, 33(1), 57–72. doi 10.1007/s10465-011-9108-4.

- Koch, S. C., Caldwell, C. & Fuchs, T. (2013). On body memory and embodied therapies. *Body, Movement and Dance in Psychotherapy*, 8(2), 82-94. doi:10.1080/17432979.2013.775968.
- Koch, S., Kunz, T., Lykou, S. & Cruz, R. (2014). Effects of dance movement therapy and dance on health-related psychological outcomes: A meta-analysis. *The Arts in Psychotherapy*, 41(1) 46-64. doi.org/10.1016/j.aip.2013.10.004
- Koch, S. C., Mergheim, K., Raeke, J., Machado, C. B., Riegner, E., Nolden, J., Diermayr, G., von Moreau, D., & Hillecke, T. K. (2016). The embodied self in Parkinson's Disease: Feasibility of a single tango intervention for assessing changes in psychological health outcomes and aesthetic experience. *Frontiers in neuroscience*, 10, 287. doi.org/10.3389/fnins.2016.00287
- Koch, S. (2017). Arts and health: Active factors and a theory framework of embodied aesthetics, *The Arts in Psychotherapy*, 54, 85-91. doi.org/10.1016/j.aip.2017.02.002.
- Koch, S. (2019). Indications and contraindications in dance movement therapy: learning from practitioners' experience. *GMS Journal of Arts Therapies*, 1. doi: 10.3205/jat000006
- Koch, S., Wirtz, G., Harter, C., Weisbrod, M., Winkler, F., Pröger, A., & Herpertz, S. (2019). Embodied self in trauma and self-harm: A pilot study of effects of flamenco therapy on traumatized inpatients, *Journal of Loss and Trauma*, 24(5-6), 441-459. doi:10.1080/15325024.2018.1507472
- Konie, R. (2011). *A brief overview of Laban Movement Analysis*. <http://psychomotorischetherapie.info/website/wp-content/uploads/2015/10/LMA-Workshop-Sheet-Laban.pdf>
- Kornblum R. (2002). *Disarming the playground: Violence prevention through movement and pro-social skills*, Wood 'N' Barnes.
- Laban, R. (2011). *Mastery of movement*. (4th ed.), Revised Lisa Ullman. Dance Books.
- Laban, R. (2011). *Choreutics*, annotated and edited by Lisa Ullman, Dance Books.
- Ladd, G. W., & Mize, J. (1983). A cognitive-social learning model of social skill training. *Psychological Review*, 90(2), 127-157.
- Lakoff, G., & Johnson, M. (2002). Why cognitive linguistics requires embodied realism. *Cognitive Linguistics*, 13(3), 245-263.
- Lauffenburger, S. (2020). Something more: the unique features of dance movement therapy/psychotherapy, *American Journal of Dance Therapy*, 42, 16-32. doi.org/10.1007/s10465-020-09321-y
- Lebre, P., Dunphy, K., & Juma, S. (2020). Exploring use of MARA (Movement Assessment and Reporting App) to establish group objectives for psycho-motor interventions, *Body, Movement, Dance and Psychotherapy*. doi: 10.1080/17432979.2020.1806926
- Lee, Y.R. (1999). The effect of dance therapy on physical and psychological characteristics in the elderly. *J Korean Acad Nurs*, 29(2) 429-444. doi.org/10.4040/jkan.1999.29.2.429
- Lee, H-J., Jang, S-H., & Lee, S-Y. (2015). Effectiveness of dance/movement therapy on affect and psychotic symptoms in patients with schizophrenia, *The Arts in Psychotherapy*, 45, 64-68. doi.org/10.1016/j.aip.2015.07.003
- Leirvag, H., Pedersen, G., & Karterud, S. (2010). Long-term continuation treatment after short-term day treatment of female patients with severe personality disorders: Body awareness group therapy versus psychodynamic group therapy. *Nord. J. Psychiatry*, 64(2), 115–122.
- Levy, F. (2005). Laban Movement Analysis and Dance Therapy in the United States, In F. Levy (Ed). *Dance/movement therapy: A Healing Art*. (pp.131-164). The American Alliance for Health, Physical Education, Recreation and Dance.
- Lötzke, D., Ostermann, T., & Büssing, A. (2015). Argentine tango in Parkinson disease--a systematic review and meta-analysis. *BMC Neurol*, 5(15), 226. doi:10.1186/s12883-015-0484-0

- Lumsden, M. (2006). The affective self and affect regulation in dance movement therapy. In S. Koch and I. Brauningner (eds.) *Advances in dance/movement therapy: Theoretical perspectives and empirical findings*. pp. 29-39. Logos Verlag.
- Making Dance Matter (2019). About MARA. <https://www.makingdancematter.com.au/about/>
<https://www.makingdancematter.com.au/help/>
- Mannheim E., & Weis J. (2006) Dance/movement therapy with cancer Inpatients: Evaluation of process and outcome parameters. In S. Koch and I. Brauningner (eds.) *Advances in dance/movement therapy: Theoretical perspectives and empirical findings*. Pp. 61-72. Logos Verlag.
- Martin, L.A., Koch, S.C., Hirjak, D., & Fuchs, T. (2016). Overcoming disembodiment: The effect of movement therapy on negative symptoms in schizophrenia-A multicenter randomized controlled trial. *Front Psychol*, 7:483. doi:10.3389/fpsyg.2016.00483
- Maté, G. (2012). *In the realm of hungry ghosts*. Vintage Canada.
- McGarry, L. M., & Russo, F. A. (2011). Mirroring in dance/movement therapy: Potential mechanisms behind empathy enhancement. *The Arts in Psychotherapy*, 38, 178–184. doi.org/10.1016/j.aip.2011.04.005.
- Meekums, B. (2010). Moving towards evidence for dance movement therapy: Robin Hood in dialogue with the King. *The Arts in Psychotherapy*, 37(1), 35–41.
- Meekums, B. (2014). Becoming visible as a profession in a climate of competitiveness: The role of research. *Body, Movement and Dance in Psychotherapy*, 9(1), 23-137. doi: 10.1080/17432979.2014.885912.
- Meekums, B., Karkou, V., & Nelson, E.A. (2015). Dance movement therapy for depression. *Cochrane Database Syst Rev*. 2015(2):CD009895. doi:10.1002/14651858.CD009895.pub2
- Minieri, A. M., Reese, R.J., Miserocchi, K. M., & Pascale-Hague, D. (2015). Using participant feedback in training of future counselling psychologists: An evidence-based and social justice practice. *Counselling Psychology Quarterly*, 28(3), 305–323. doi:10.1080/09515070.2015.1055236
- Moore, C. & Yamamoto, K. (2011). *Beyond words: Movement observation and analysis*, Gordon and Breach.
- Newlove, J. & Dalby, J. (2004). *Laban for All*, London:Nick Hern Books.
- Noreau, L., Martineau, H., Roy, L., Belzile, M. (1995). Effects of a modified dance-based exercise on cardiorespiratory fitness, psychological state and health status of persons with rheumatoid arthritis. *American Journal of Physical Medicine & Rehabilitation*, 74(1):19-27. doi: 10.1097/00002060-199501000-00004.
- NSW Government (2019). NSW Human Services Outcomes Framework. NSW Government. <https://www.facs.nsw.gov.au/resources/human-services-outcomes-framework>
- Oranga Tamariki Ministry for Children (n.d) *Outcomes framework*. New Zealand Government. <https://orangatamariki.govt.nz/about-us/outcomes-framework/>
- Panksepp, J. (2005). On the embodied neural nature of core emotional affects. *Journal of Consciousness Studies*, 12(8-10), 158–184.
- Peters, H. J. (2012). *Dance/dance movement therapy and general wellbeing, depression and anxiety: A meta-analysis* (Doctoral dissertation), University of Tasmania.
- Pohlmann, V., Koch, S., & Fuchs, T. (2017). Changes in Well-Being of Schizophrenic Patients after Movement Therapy: Results of a Multicenter RCT Study. In K. Dannecker (Ed.). *Arts Therapies and New Challenges in Psychiatry*, pp. 114-139. Routledge.
- Powell, M. (2008). *Assessment in dance/movement therapy practice: A state of the field survey*, Masters thesis, Drexel University. <http://dspace.library.drexel.edu/handle/1860/2944>
- Rodrigues-Krause, J., Farinha, J.B., Krause, M., & Reischak-Oliveira, Á. (2016). Effects of dance interventions on cardiovascular risk with ageing: Systematic review and meta-analysis. *Complement Ther Med*. 29, 16-28. doi:10.1016/j.ctim.2016.09.004

- Röhrich, F., & Priebe, S. (2006). Effect of body-oriented psychological therapy on negative symptoms in schizophrenia: a randomized controlled trial. *Psychol Med.* 36(5):669-678. doi:10.1017/S0033291706007161
- Rogers, N. (2016). Person-centered expressive art therapy: A path to wholeness. In J. Rubin (Ed) *Approaches to Art Therapy: Theory and Technique*. Routledge.
- Samaritter, R. (2018). The aesthetic turn in mental health: Reflections on an explorative study into practices in the arts therapies, *Behav. Sci*, 8, 41; doi:10.3390/bs8040.
- Schifferstein, H.N.J. & Hekkert, P. (2013). Sensory aesthetics in product design. In F. Bacci and D. Melcher (Eds.) *Art and the senses*. Oxford University Press, pp. 529-555.
- Seligman, M. (2011). *Flourish: A visionary new understanding of happiness and well-being*. Heinemann.
- Shanahan, J., Morris, M.E., Bhriain, O.N., Saunders, J., & Clifford, A.M. (2014). Dance for people with Parkinson disease: what is the evidence telling us? *Arch Phys Med Rehabil.*, 96(1)141-153. doi.org/10.1016/j.apmr.2014.08.017
- Sharp, K., & Hewitt, J. (2014). Dance as an intervention for people with Parkinson's disease: a systematic review and meta-analysis. *Neurosci Biobehav Rev.* 47,445-456. doi:10.1016/j.neubiorev.2014.09.009.
- Sheets-Johnstone, M. (2016). Foundational dynamics of animate nature. In U. Eberlein (Ed.). *Intercorporeality, movement and tacit knowledge*. transcript Verlag.
- Shimamura, A.P. (2014). Toward a science of aesthetics: issues and ideas. In A.P. Shimamura and S.E. Palmer (Eds.). *Aesthetic science: Connecting minds, brains and experience*. Oxford University Press, pp. 2-28.
- Stanley, E. (2019). *Widen the window: Training your brain and body to thrive during stress and recover from trauma*. Yellow Kite, Hodder & Stoughton.
- State of Victoria, Department of Health and Human Services. (2016). Victorian public health and wellbeing outcomes framework. Melbourne: Victorian Government. <http://www.dhhs.vic.gov.au/our-strategy>.
- Stern, D. (2010). *Forms of vitality: Exploring dynamic experience in psychology, the arts, psychotherapy and development*. Oxford University Press.
- Studd, K. & Cox, L. (2013). *Everybody Is a body*. Dog Ear Publishing.
- Summa, M., Koch, S., Fuchs, T., & Muller, C. (2013). Body memory: an integration. In: Koch, S., Fuchs, T., Summa, M., & Muller, C. (eds). *Body Memory, Metaphor and Movement*. John Benjamin
- Takahashi, H., Matsushima, K., & Kato, T. (2019). The effectiveness of dance/movement therapy for autism spectrum disorder: A systematic review. *American Journal of Dance Therapy* <https://doi.org/10.1007/s10465-019-09296-5> 1 3
- Thompson, G. (2020). A grounded theory of music therapists' approach to goal processes within their clinical practice, *The Arts in Psychotherapy*, 70,101680. doi:<https://doi.org/10.1016/j.aip.2020.101680>.
- Todd, M. (1997). *The Thinking Body*. Gestalt Press.
- Tsachor, R., & Shafir, T. (2019). How shall I count the ways? A method for quantifying the qualitative aspects of unscripted movement with Laban Movement Analysis. *Frontiers in Psychology*. doi: 10.3389/fpsyg.2019.00572.
- Ullmann, L. (1971). *Some preparatory stages for the study of space harmony in the art of movement*, The Laban Art of Movement Guild.
- UNESCO (2001). Universal Declaration on Cultural Diversity. http://portal.unesco.org/en/ev.php-URL_ID=13179&URL_DO=DO_TOPIC&URL_SECTION=201.html
- UNESCO (2020). What is meant by "cultural heritage"? <http://www.unesco.org/new/en/culture/themes/illicit-trafficking-of-cultural-property/unesco-database-of-national-cultural-heritage-laws/frequently-asked-questions/definition-of-the-cultural-heritage/>

Vancea, F. (2013). Unifying Personal Development Through Dance, Movement and the Increase of the Emotional Intelligence Level. *J Exp Psychother. Psihoter. Exp.* 16:3.

Van der Kolk, B. (2014). *The body keeps the score: Brain, mind, and body in the healing of trauma*. Penguin.

Wengrower, H. (2016). The creative artistic process in dance movement therapy, in S. Chaiklin, & H. Wengrower, (eds.). *The Art and Science of Dance/Movement Therapy* (pp. 13-32). Routledge.

Welsh Government (2016). *Social Services: The national outcomes framework for people who need care and support and carers who need support*. Welsh Government. <https://socialcare.wales/research-and-data/research-on-care-finder/the-national-outcomes-framework-for-people-who-need-care-and-support-and-carers-who-need-support>

World Health Organisation (2020). Constitution. <https://www.who.int/about/who-we-are/constitution>